



CP RACK

Quick Reference Guide

Scan the QR code to access the product page and warranty terms.

English	EN
Español	ES
Français	FR
Deutsch	DE
Nederlands	NL

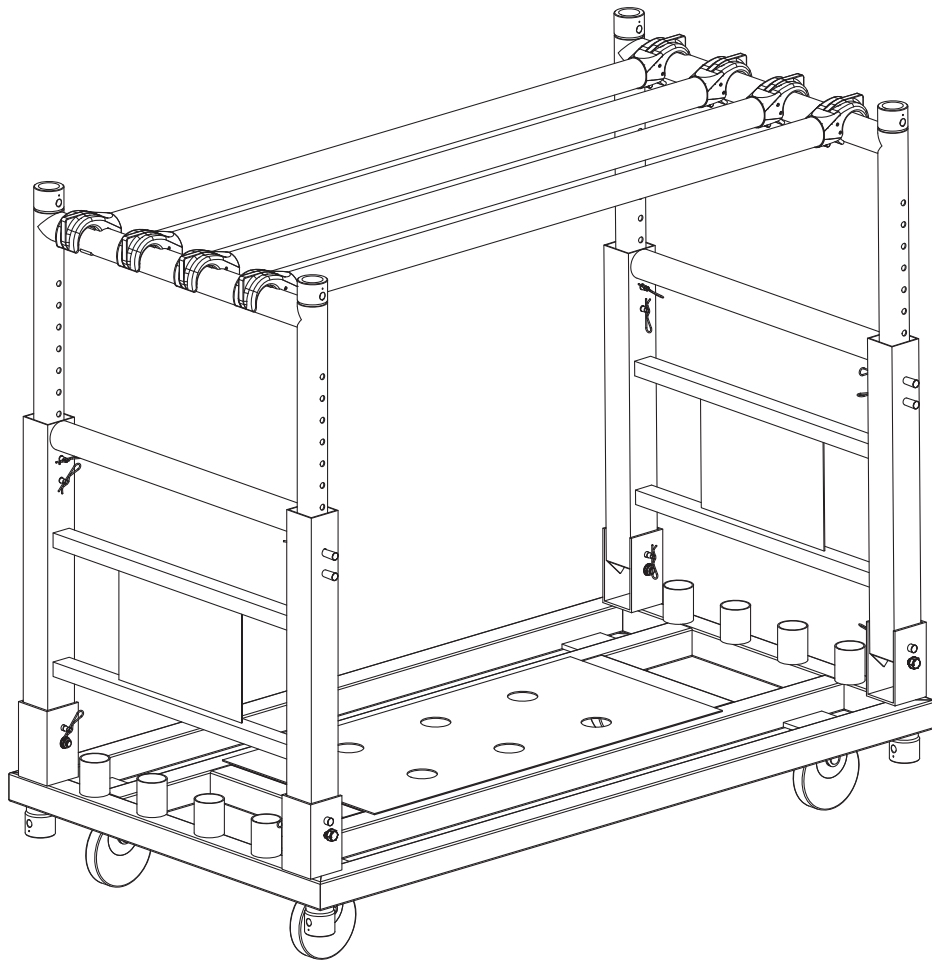

Model ID: CPRACK

Intentionally Left Blank Page

Safety Notes

These Safety Notes include important information about installation, use, and maintenance of the CP Rack.

- **DO NOT:**





- Leave outdoors in locations with extreme environmental conditions. This includes, but is not limited to:
 - Exposure to a marine/saline environment (within 3 miles of a saltwater body of water).
 - Locations where normal temperatures exceed the temperature ranges in this manual.
 - Locations that are prone to flooding or being buried in snow.
 - Other areas where the product will be subject to extreme radiation or caustic substances.
- In the event of a serious operating problem, stop using immediately.

What is Included

- CP Rack
- Cover
- Quick Reference Guide

Symbols

Symbol	Meaning
	Critical installation, configuration, or operation information. Not following these instructions may make the product not work, cause damage to the product, or cause harm to the operator.
	Important installation or configuration information. The product may not function correctly if this information is not used.
	Useful information.

Product Overview

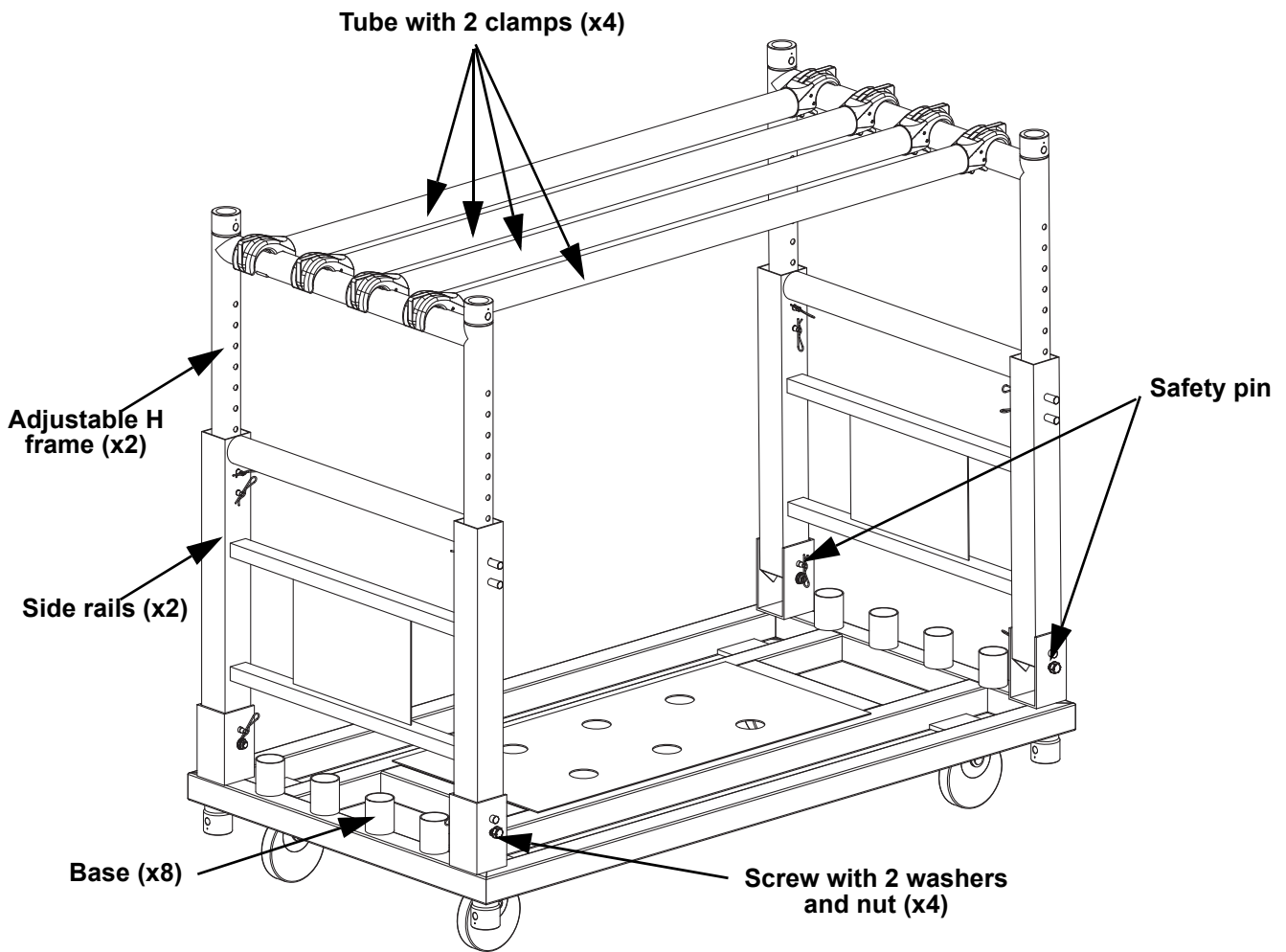

Setup

1. To begin setup:
 - a. Raise each side rail of the CP Rack by removing the pins at the base of each side rail.

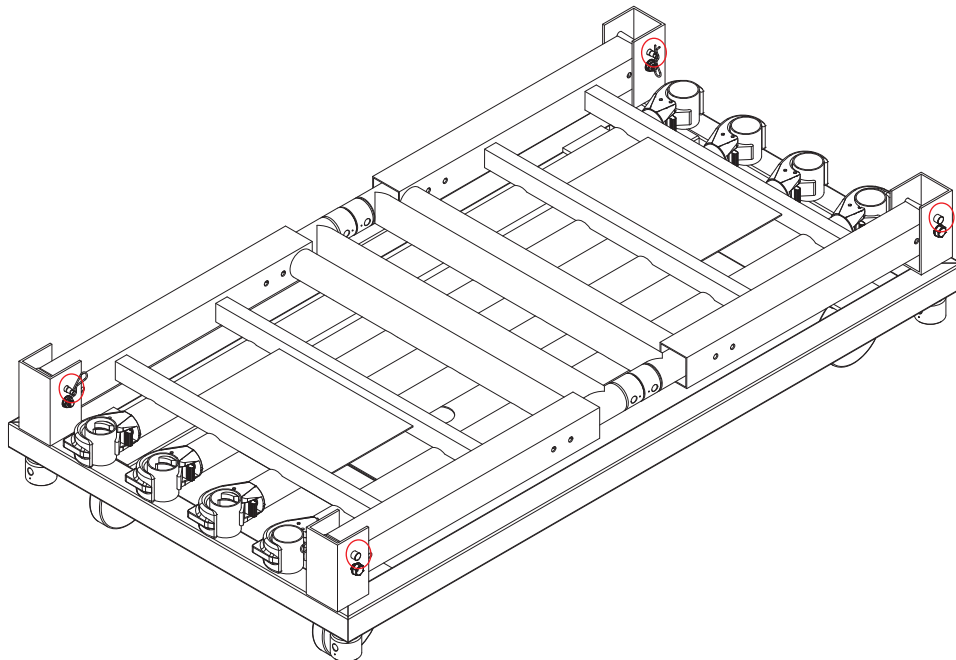

- b. To remove the pin, remove the safety clip first.

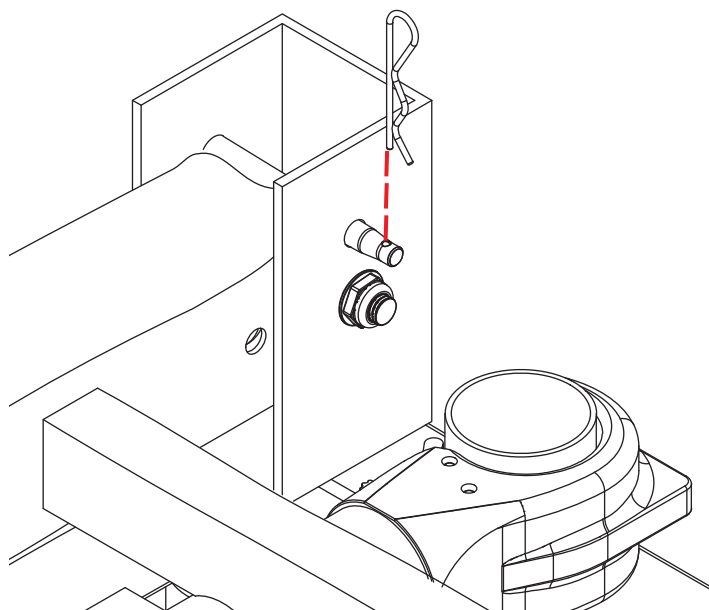

c.

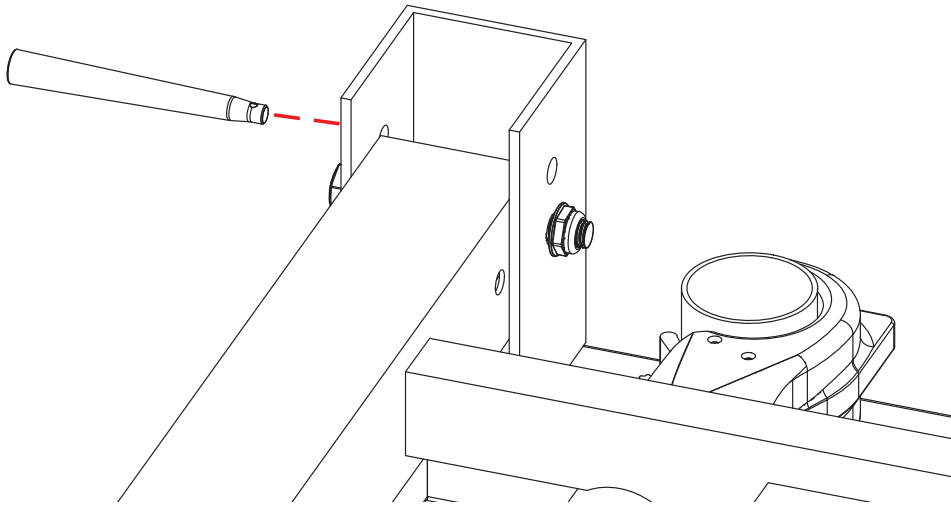

d.

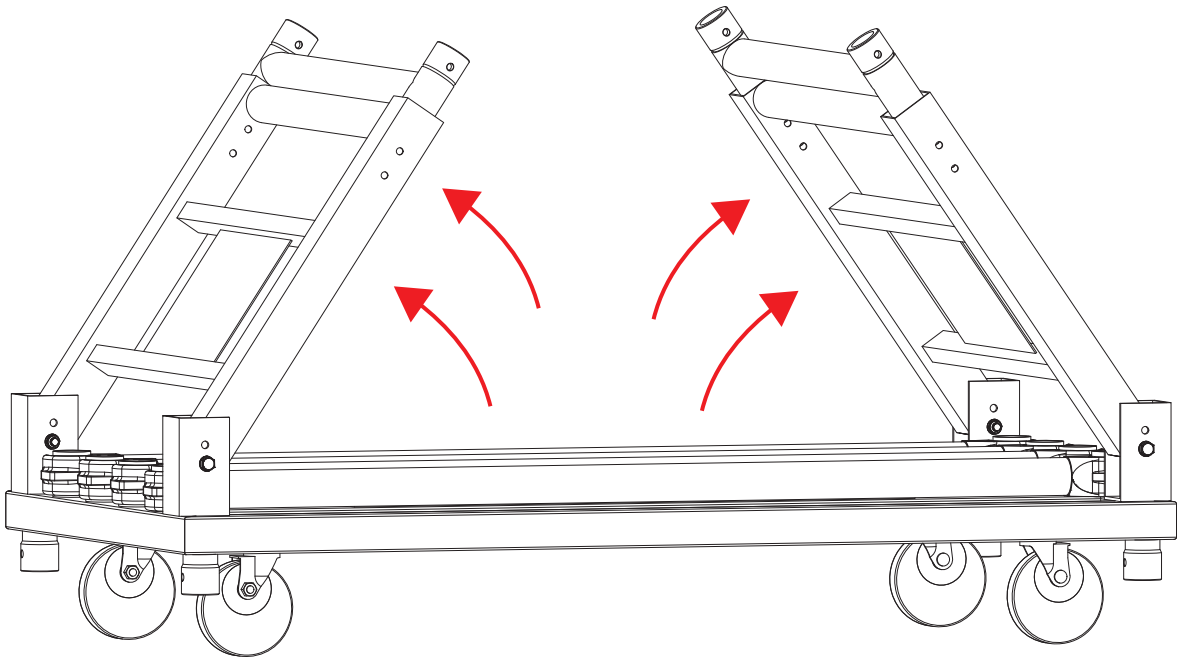

e.

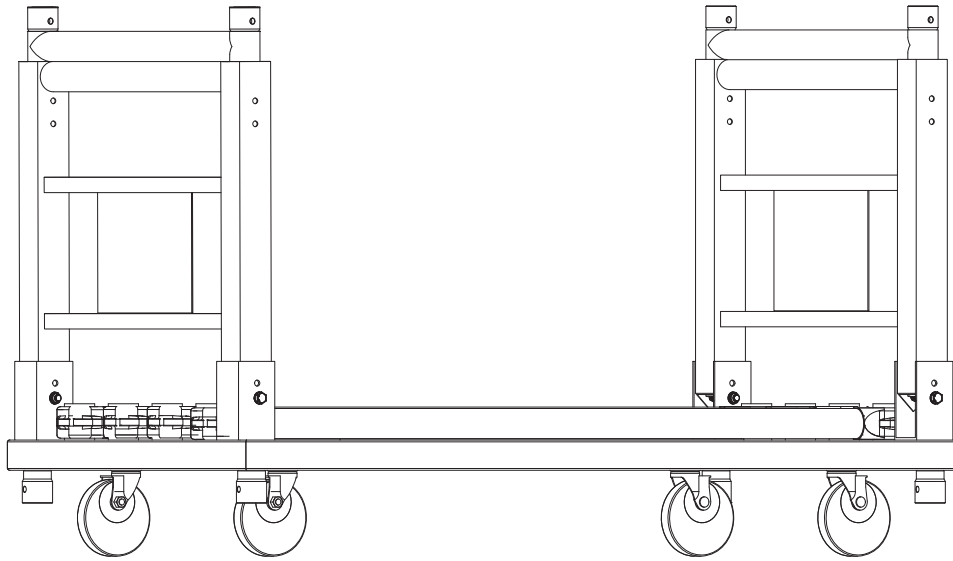

It is possible to remove both of the H frames from the CP Rack. The H frames may then be hung from a truss.

f. Insert the pin to lock the side rail into upright position.

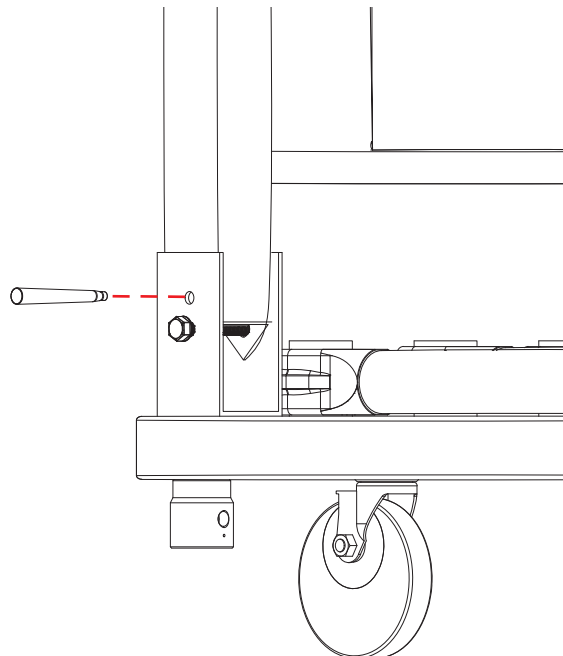

g. Insert the safety clip into the pin.

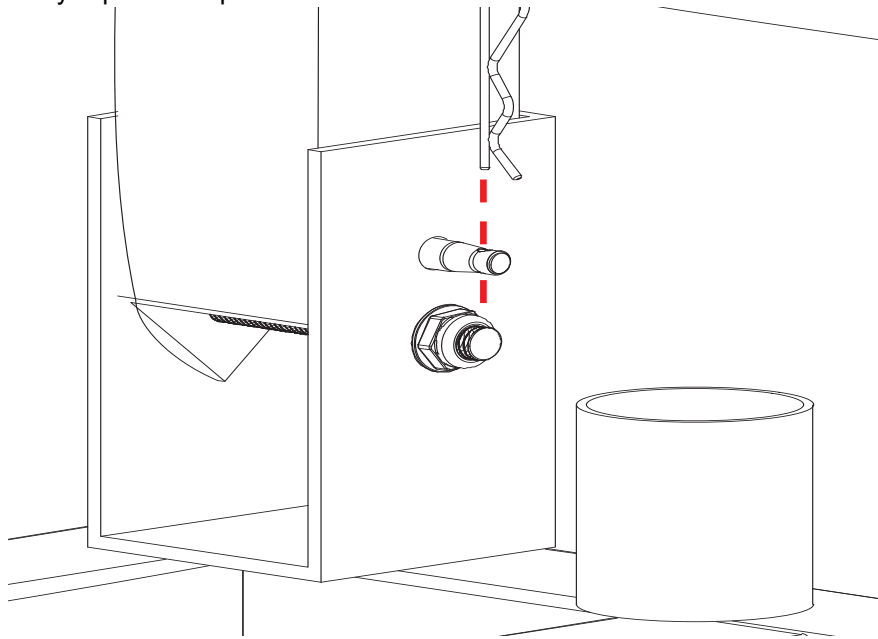

h. Repeat steps 1-f and 1-g with all bases to lock the side rails.

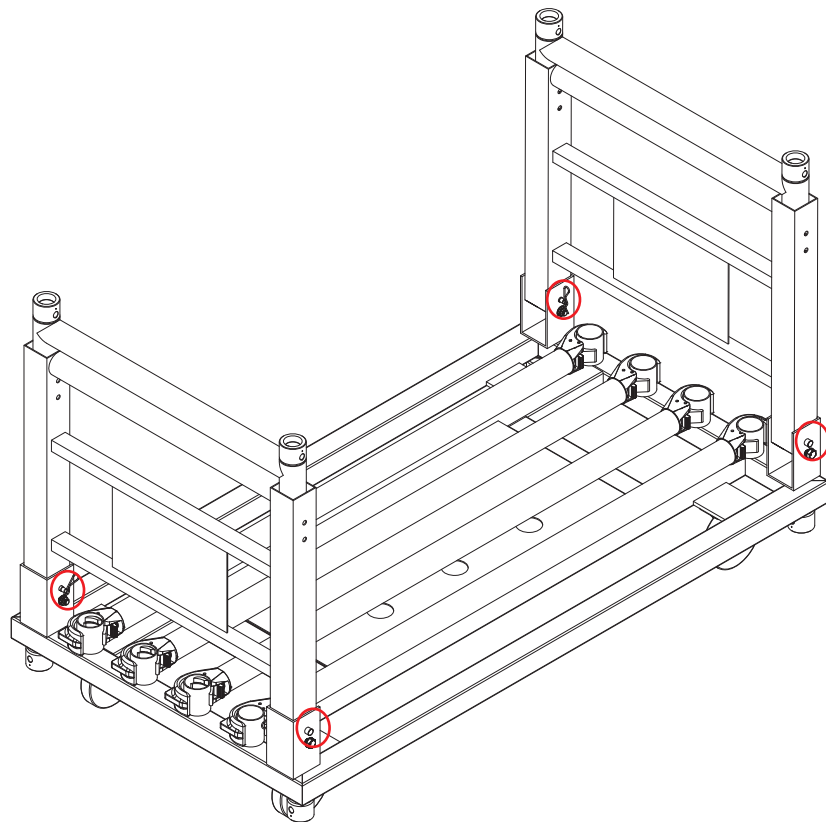

Warning! Ensure that all attachment points are fully tightened. Failure to do so may cause safety hazards!

- 2. To detach the tubes from bases:
 - a. Release the clamp by depressing the switch.

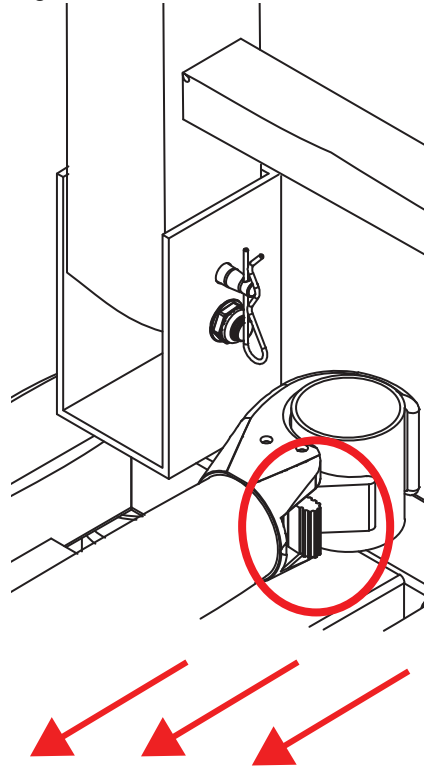

- b. Remove the tube.

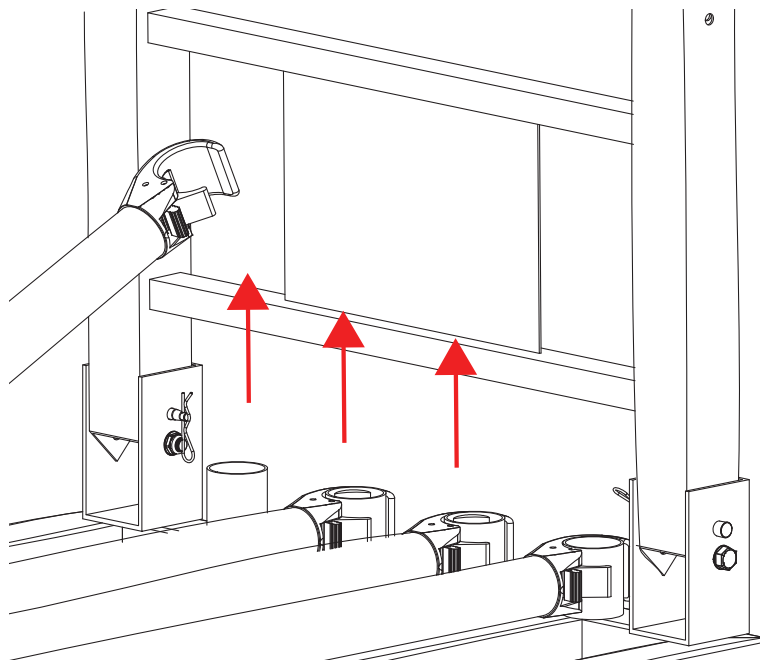

- c. Repeat the process with the other clamp to release the tube completely.

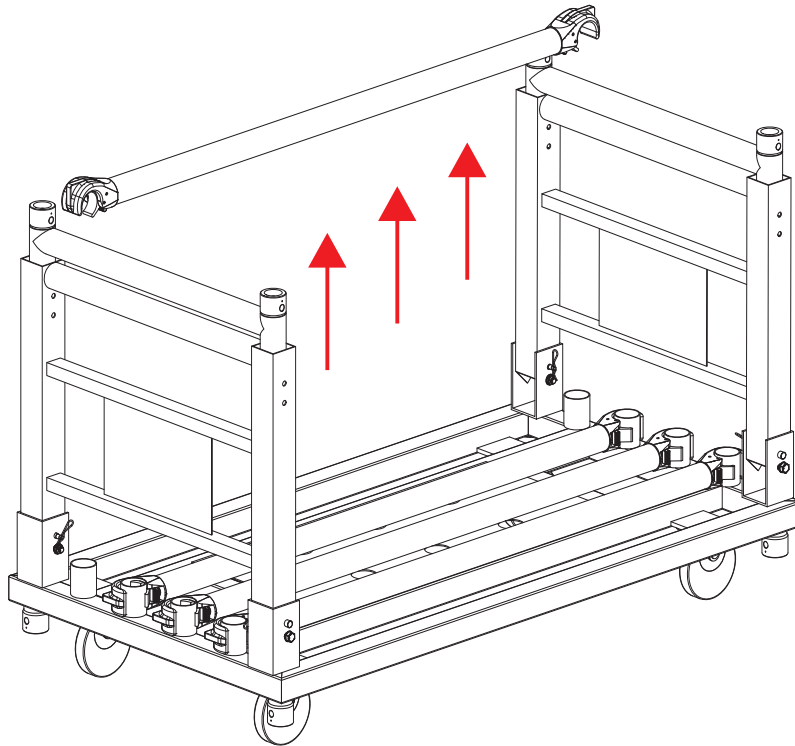

- 3. To connect the tube(s) to the H frames:

- a. Ensure that the clamp is facing down and press the clamp onto the horizontal bar of the H frame.

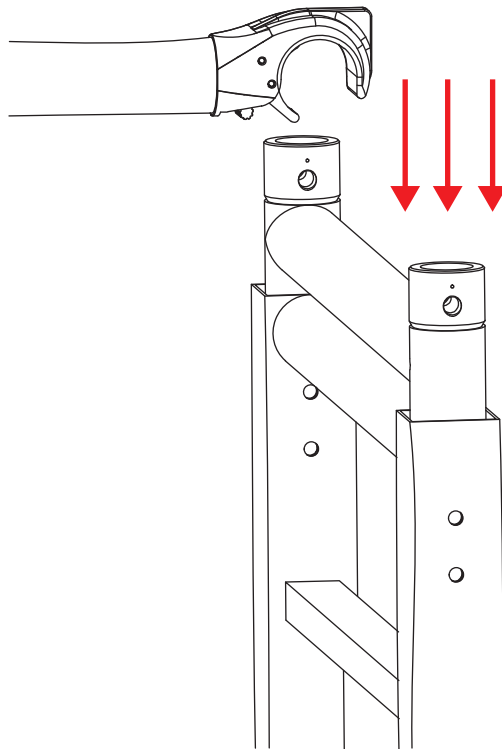

- b. Ensure that the clamp is firmly attached to the H frame.

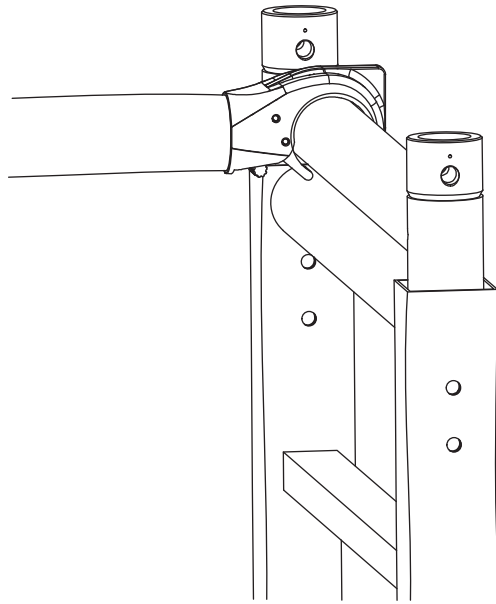

- c. Repeat the previous steps with any other desired tubes:

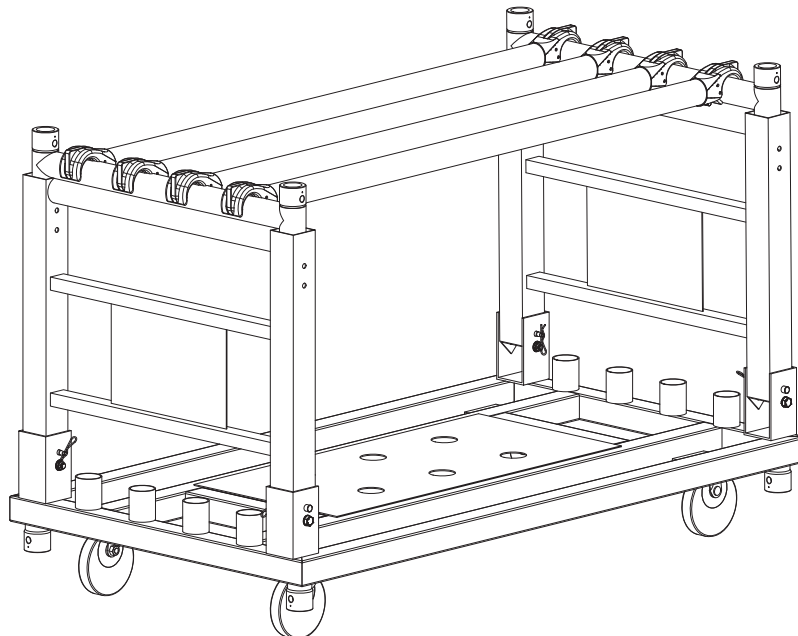

The maximum load capacity for this product is 1,000 lbs. Do not exceed this weight, as failure to do so may cause safety hazards.

4. It is possible to extend the H frames to double the height of the CP Rack. To extend the H frames:
 - a. Remove safety clips locking H frame in place.
 - b. Extend or lower the pin to the desired height.

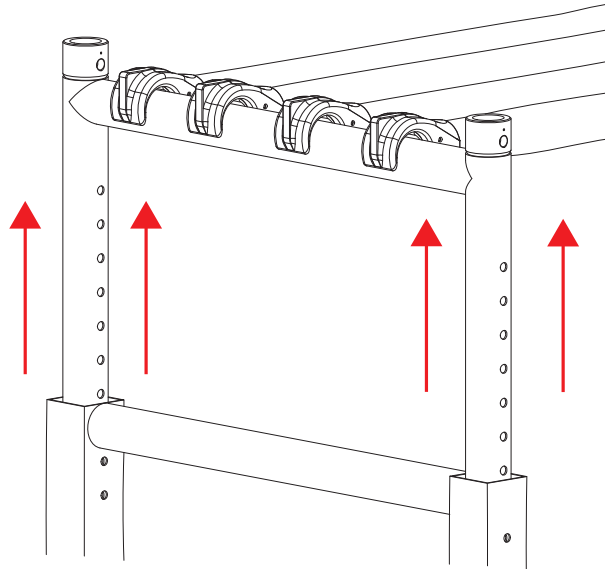

- c. Re-insert the safety clips and pins to stabilize the H frames at the desired height.

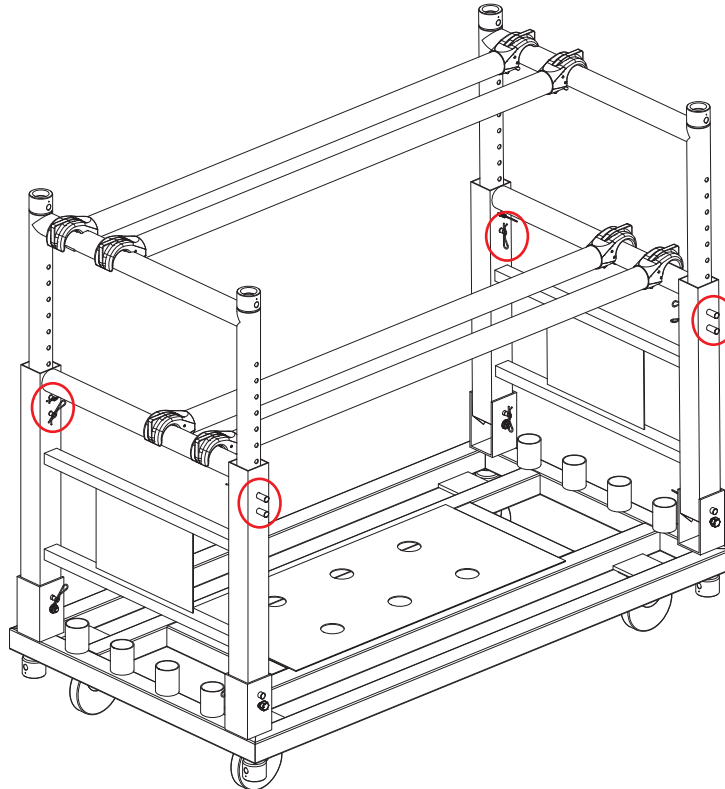

It is possible to stack another CP Rack on top of this product. Maximum stacking is 2 products high.

Transporting on Truss or Racks

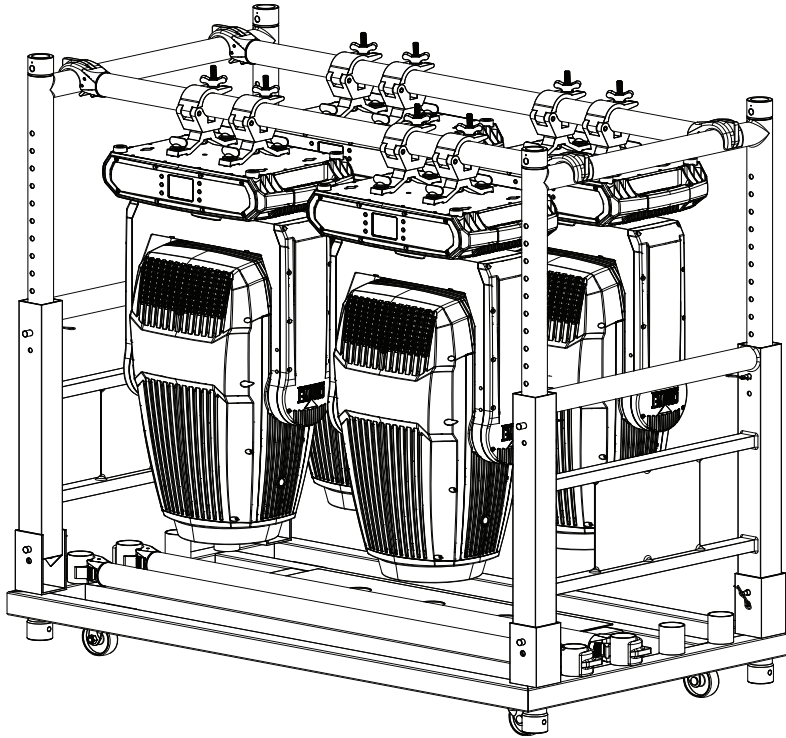

When transporting fixtures in pre-rigged truss and transportation racks, mount fixtures in the vertical position with the lenses facing down and the pan and tilt locks engaged. This is to prevent undue stress on the tilt locks and limit the amount of off-axis bounce on internal components.

Notas de seguridad

Estas notas de seguridad incluyen información importante sobre la instalación, el uso y el mantenimiento del CP Rack.

- **NO HACER:**





- Instalar permanentemente en el exterior en lugares con condiciones ambientales extremas. Esto incluye, pero no se limita a:
 - Exposición a un entorno marino/salino (a menos de 3 millas de una masa de agua salada).
 - Lugares donde las temperaturas normales superan los rangos de temperatura de este manual.
 - Lugares propensos a las inundaciones o a quedar enterrados en la nieve.
 - Otras zonas en las que el producto esté sometido a radiaciones extremas o a sustancias cáusticas.
- En caso de un problema grave de funcionamiento, deje de usarlo inmediatamente.

Qué se incluye

- CP Rack
- Cobre
- Guía de referencia rápida

Simbolos

Símbolo	Significado
	Instalación, configuración o información sobre funcionamiento crítica. Hacer caso omiso de esta información puede hacer que el producto no funcione, que se averíe, o causar daños al usuario.
	Instalación o información de configuración importante. El producto puede no funcionar correctamente si esta información no se usa.
	Información útil.

Descripción del producto

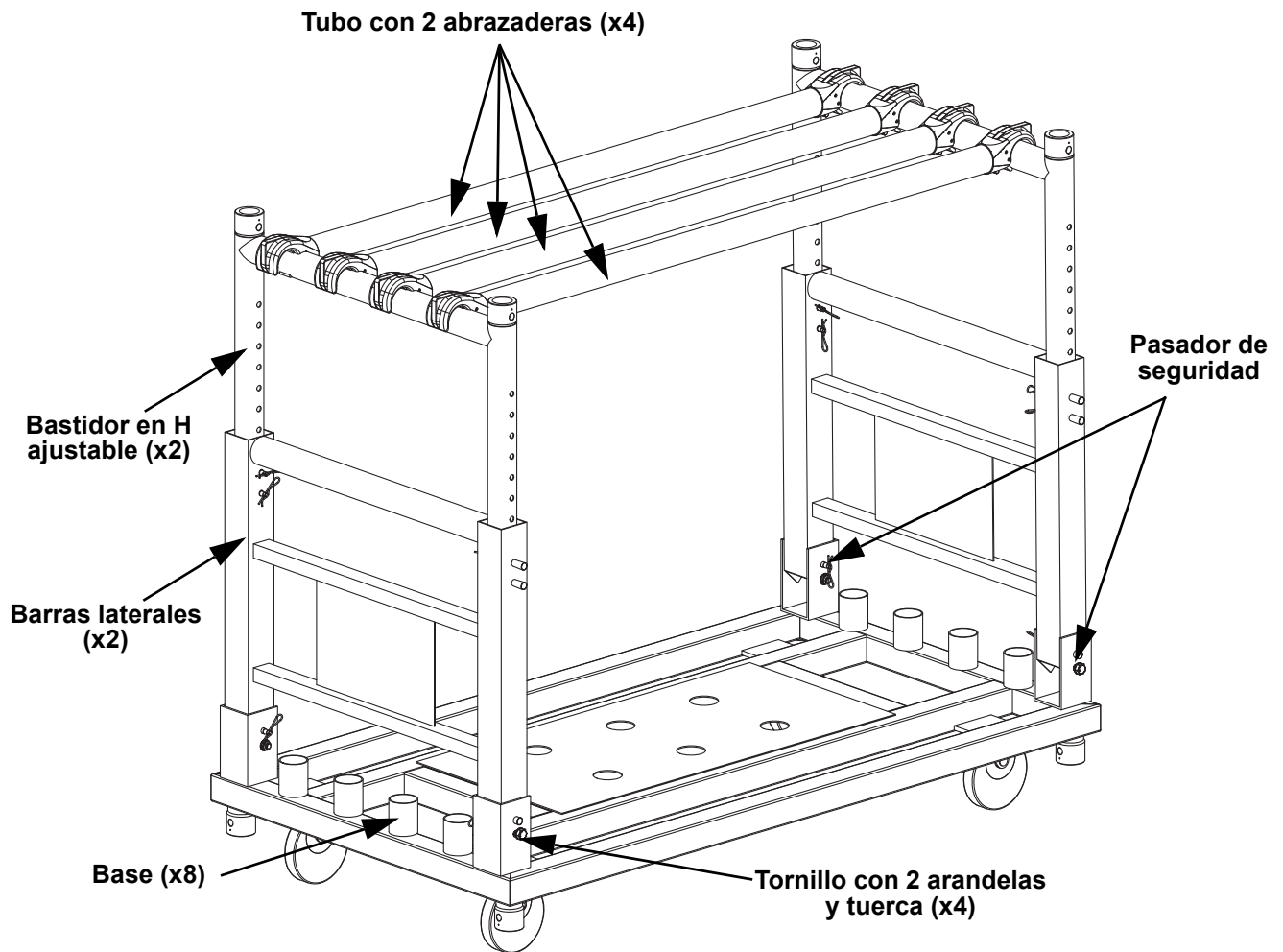

Montaje

1. Para comenzar el montaje:
 - a. Levante cada barra lateral del CP Rack retirando los pasadores de la base de cada barra lateral.

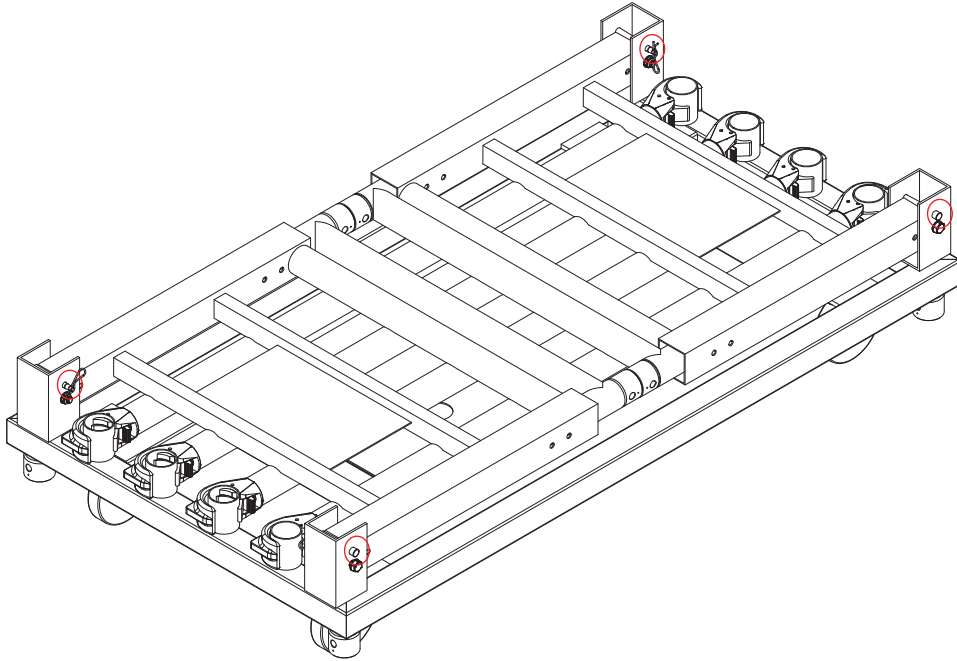

- b. Para extraer el pasador, retire primero el clip de seguridad.

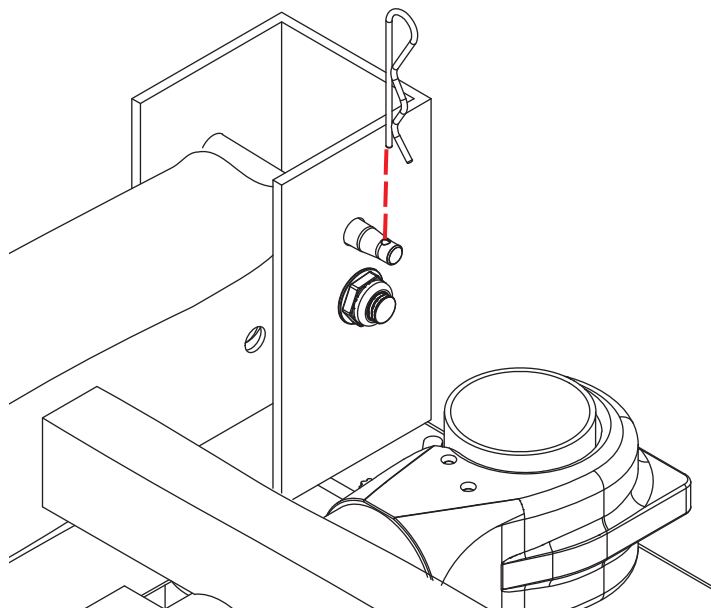

c.

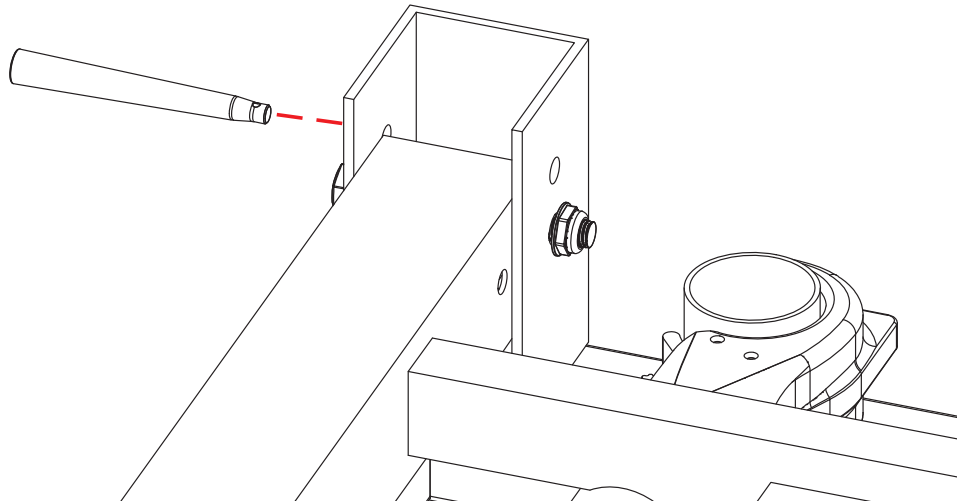

d.

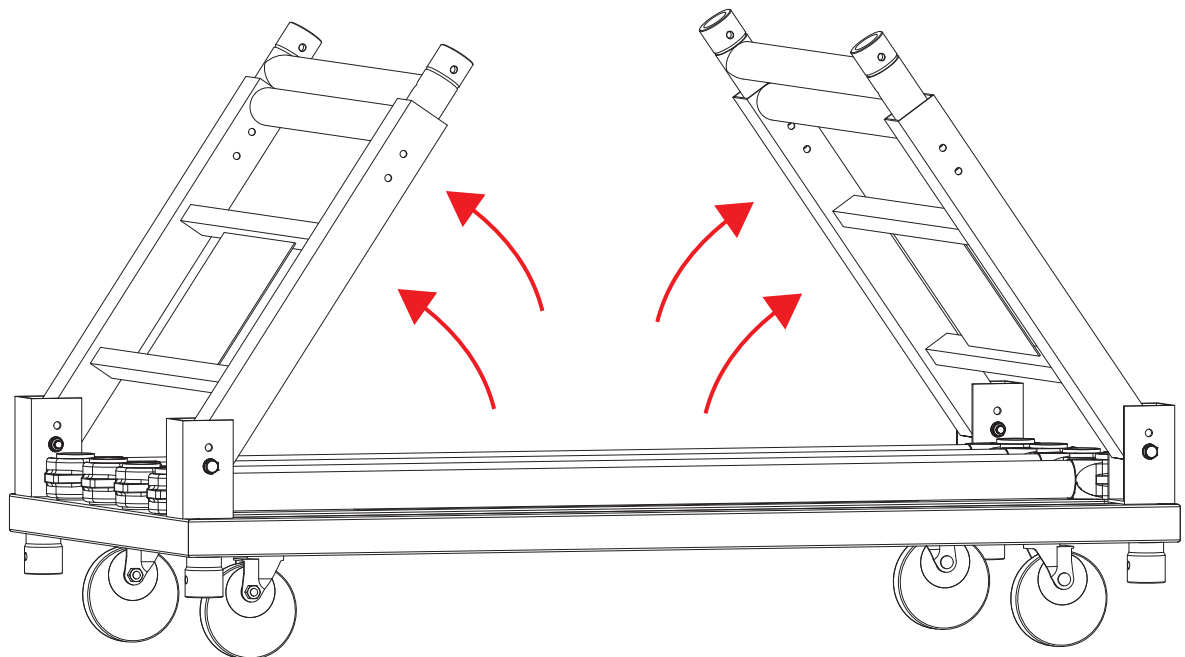

e.

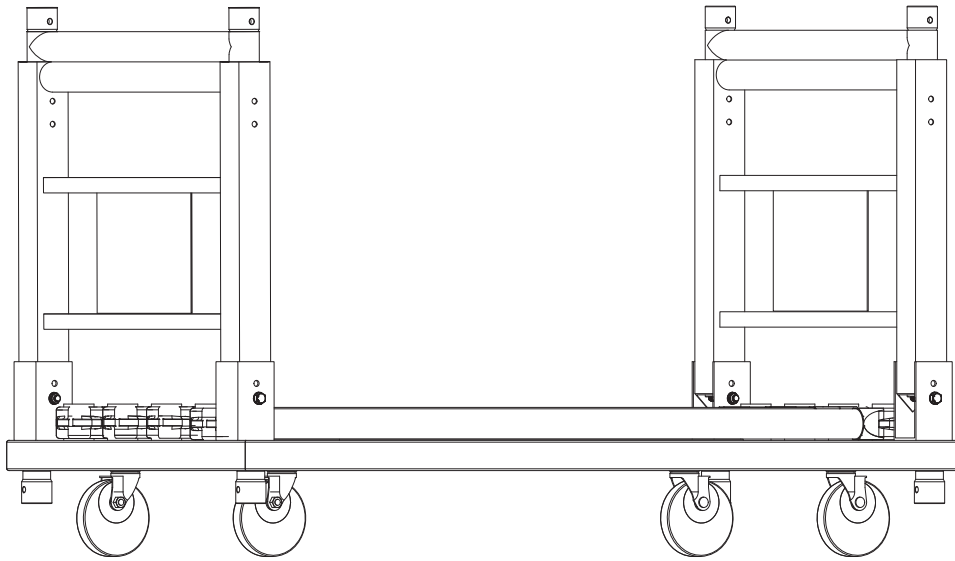

Es posible retirar los dos bastidores en H del CP Rack. Después los bastidores en H pueden colgarse de un armazón.

f. Inserte el pasador para bloquear la barra lateral en posición vertical.

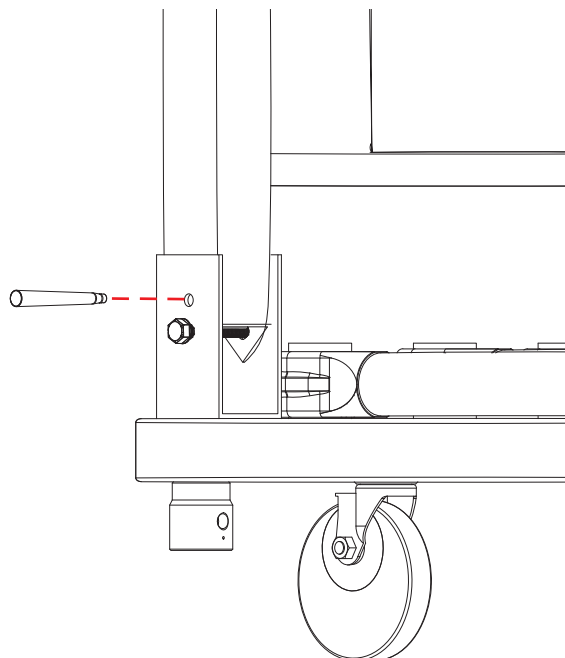

g. Inserte el clip de seguridad en el pasador.

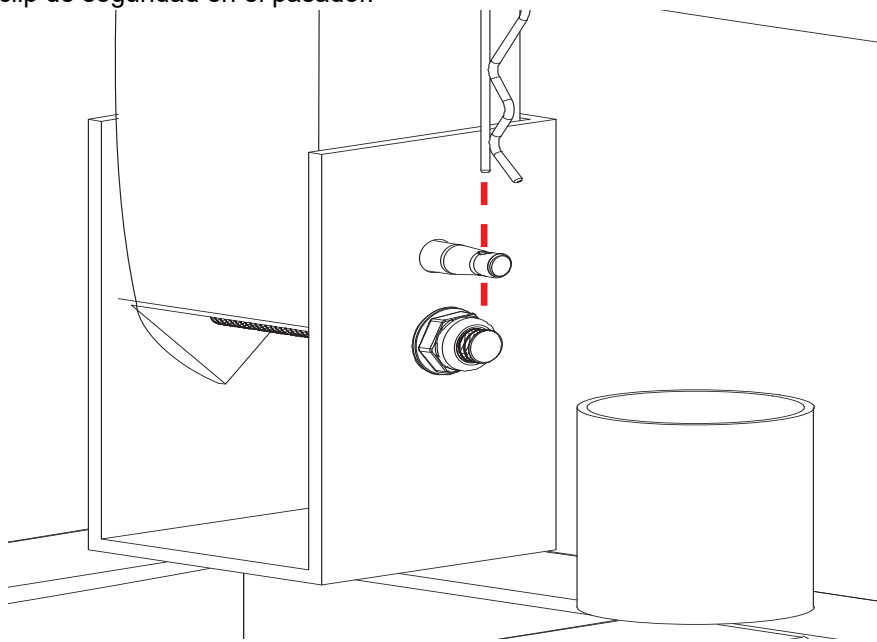

h. Repita los pasos 1-f y 1-g con todas las bases para bloquear las barras laterales.

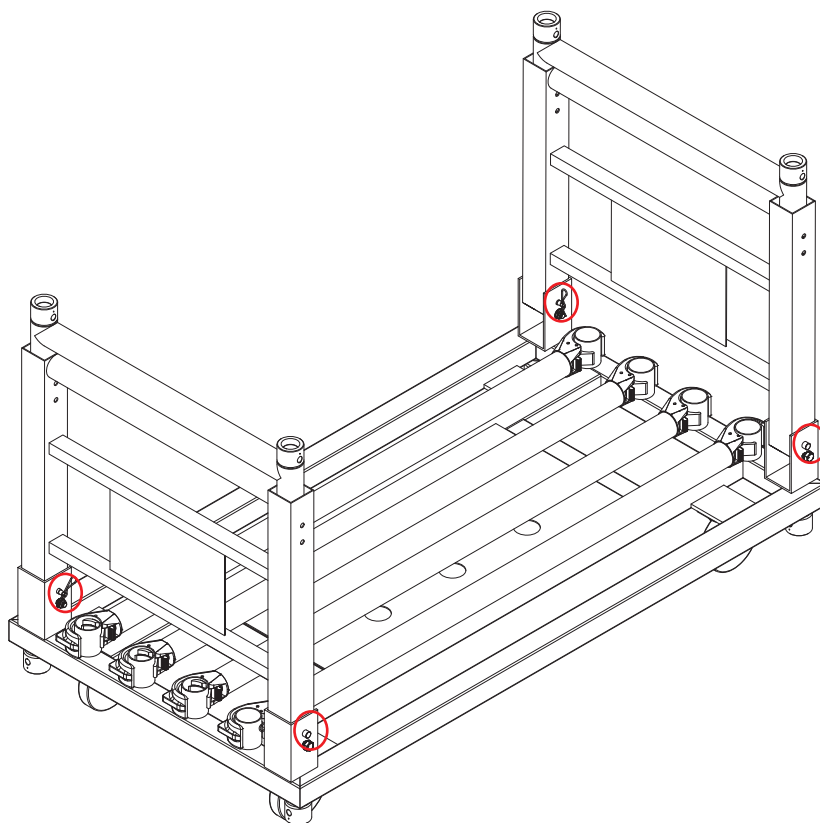

¡Advertencia! Asegúrese de que todos los puntos de fijación estén completamente apretados. Si no lo hace, puede provocar riesgos para la seguridad.

ES

2. Para separar los tubos de las bases:
 - a. Suelte la abrazadera presionando el interruptor.

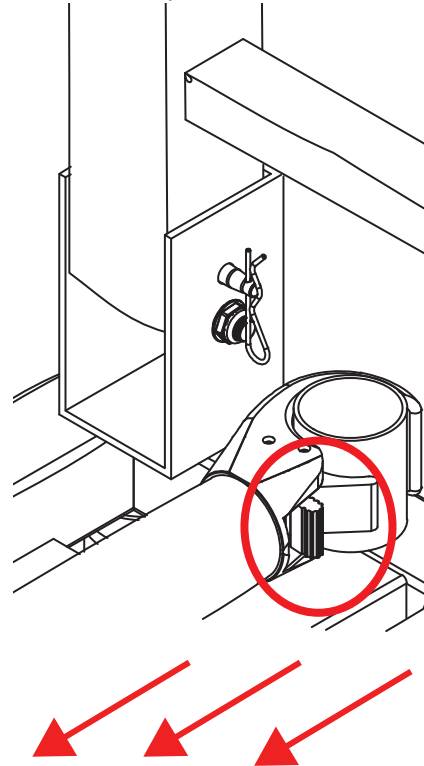

- b. Retire el tubo.

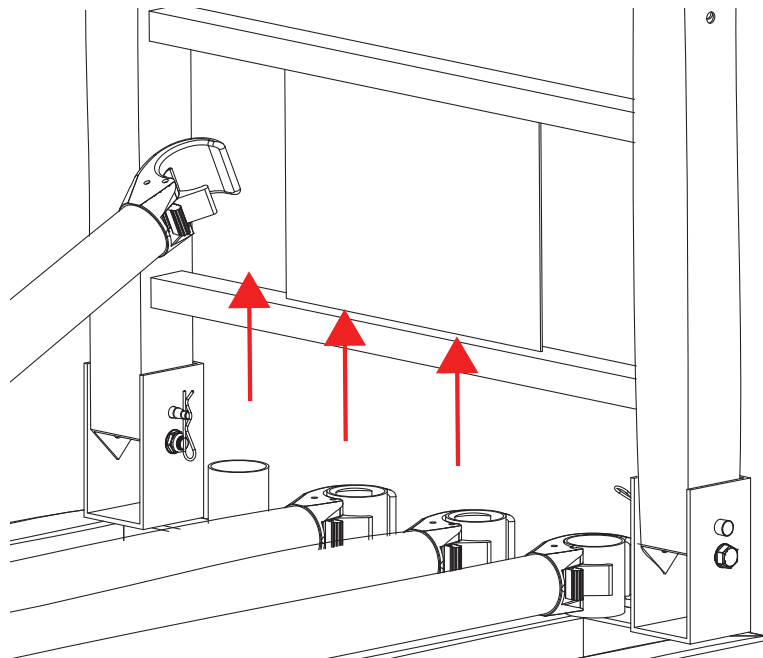

- c. Repita el proceso con la otra abrazadera para liberar completamente el tubo.

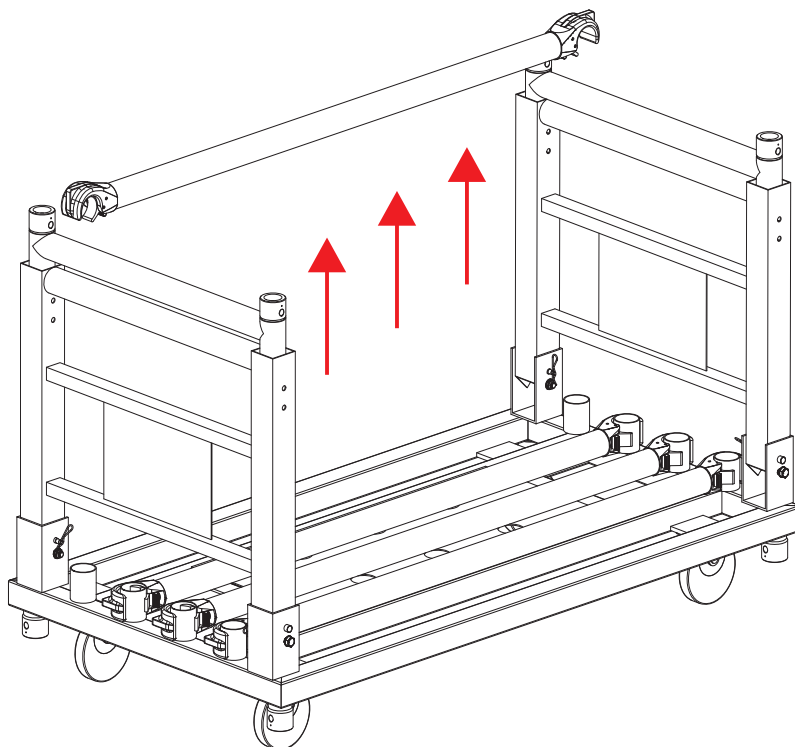

3. Para conectar los tubos a los bastidores en H:

- a. Asegúrese de que la abrazadera esté orientada hacia abajo y presiónela sobre la barra horizontal del bastidor en H.

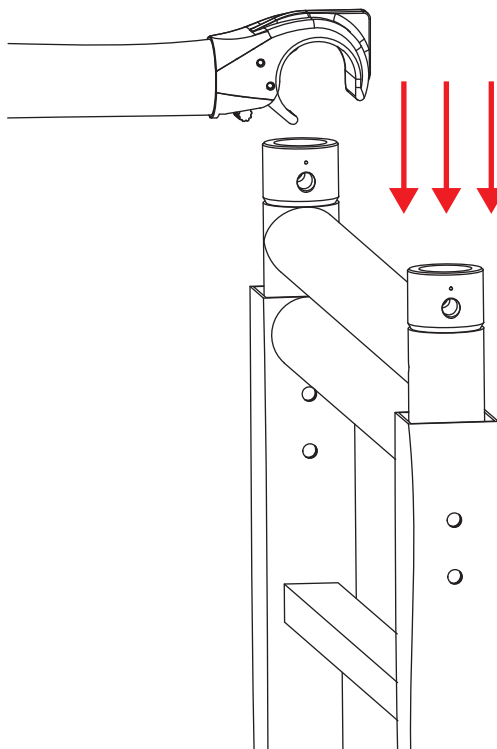

- b. Asegúrese de que la abrazadera esté firmemente sujeta al bastidor en H.

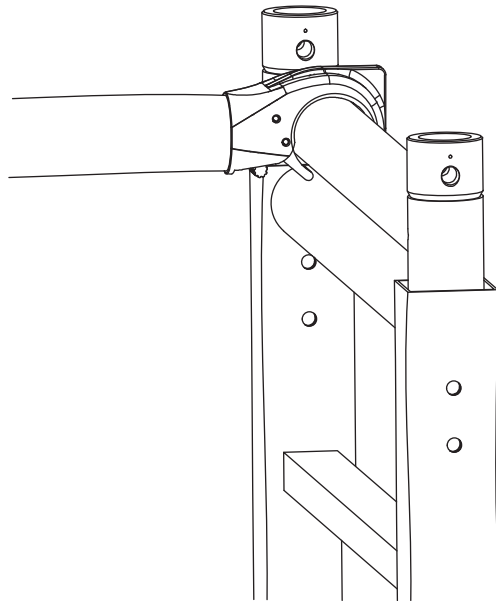

- c. Repita los pasos anteriores con los demás tubos que desee:

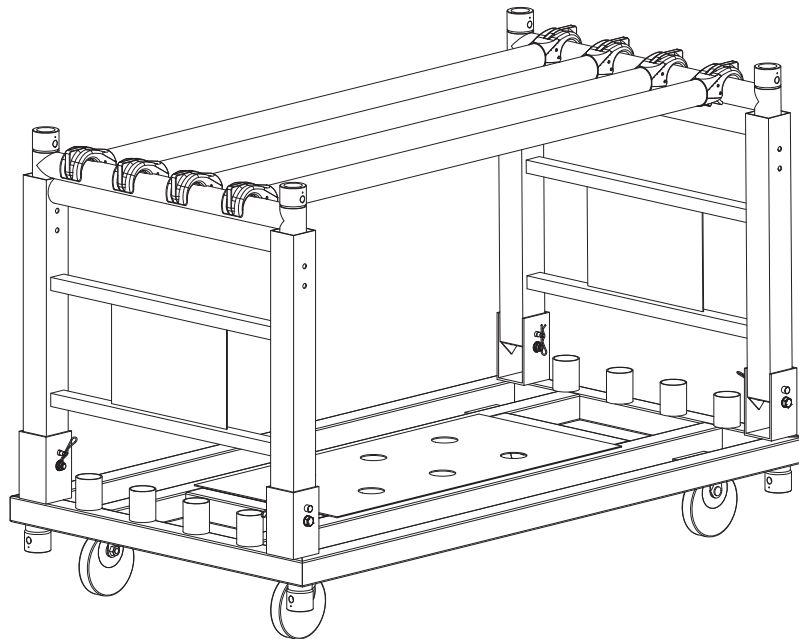

La capacidad de carga máxima de este producto es de 450 kg. No supere este peso, ya que de lo contrario puede provocar riesgos para la seguridad.

4. Es posible ampliar los bastidores en H para duplicar la altura del CP Rack. Para ampliar los bastidores en H:
 - a. Retire los clips de seguridad que bloquean el bastidor en H en su sitio.
 - b. Extienda o baje el pasador hasta la altura deseada.

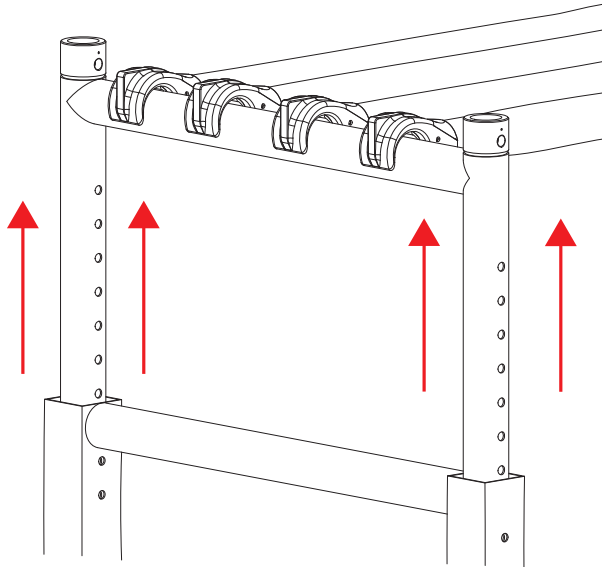

- c. Vuelva a colocar los clips de seguridad y los pasadores para estabilizar los bastidores en H a la altura deseada.

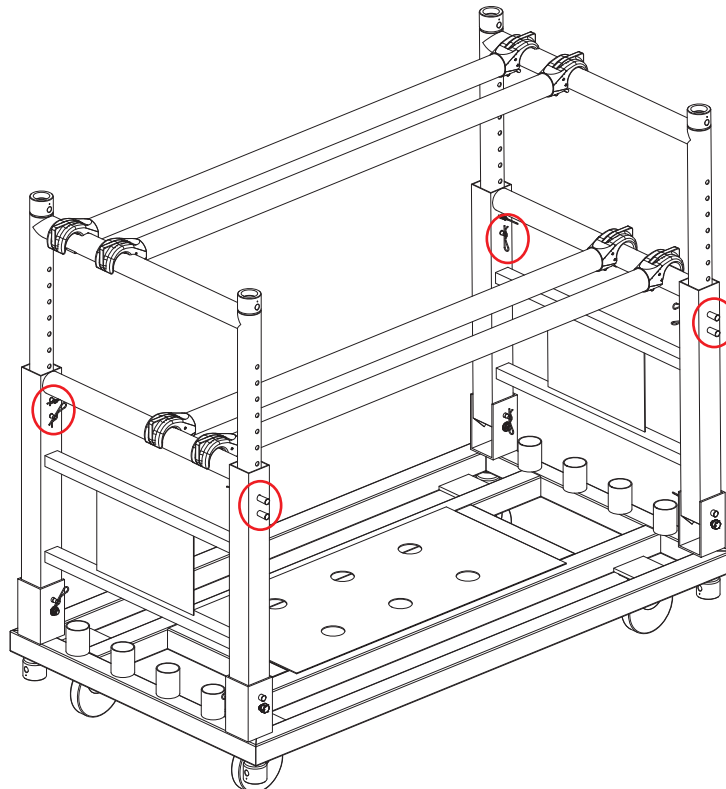

Es posible apilar otro CP Rack sobre este producto. El apilado máximo en altura es de 2 productos.

Transporte en armazón o bastidores

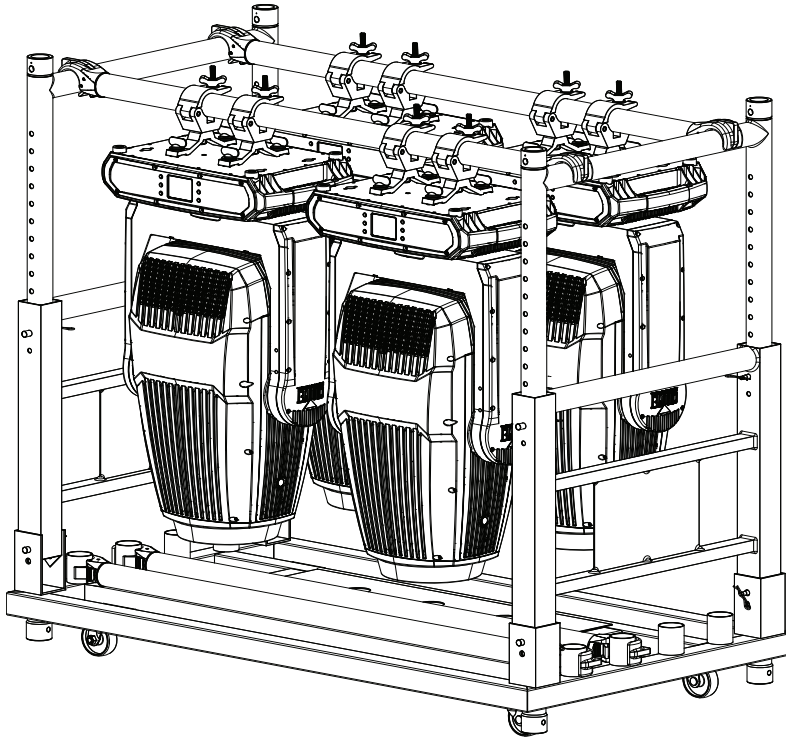

Cuando transporte dispositivos en armazones y bastidores de transporte preinstalados, monte los dispositivos en posición vertical con los lentes hacia abajo y los bloqueos de giro e inclinación activados. Esto permite evitar tensiones indebidas en los bloqueos de inclinación y limitar la cantidad de rebote fuera del eje en los componentes internos.

Consignes de sécurité

Ces consignes de sécurité contiennent des informations importantes sur l'installation, l'utilisation et l'entretien de CP Rack.





- **NE PAS :**
 - Installer de manière permanente dans des endroits avec des conditions environnementales extrêmes. Cela inclut, mais sans toutefois s'y limiter à :
 - Exposition à un environnement marin/salin (à moins de 3 miles d'une étendue d'eau salée).
 - Emplacements où les températures normales dépassent les plages de températures indiquées dans ce manuel.
 - Emplacements susceptibles d'être inondés ou d'être ensevelis sous la neige.
 - Autres zones où le produit sera soumis à des radiations extrêmes ou à des substances caustiques.
 - En cas de problème de fonctionnement grave, arrêter immédiatement de l'utiliser.

Contenu de la boîte

- CP Rack
- Couverture
- Guide de référence rapide

Symboles

Symbole	Signification
	Consignes importantes en matière d'installation, de configuration et de fonctionnement. Le non-respect de ces consignes peut entraîner le non-fonctionnement de l'appareil ou lui causer des dommages. De même, l'utilisateur peut s'en trouver affecté.
	Consignes importantes en matière d'installation ou de configuration. Le produit peut ne pas fonctionner correctement si ces instructions ne sont pas suivies.
	Informations utiles.

FR

Aperçu du produit

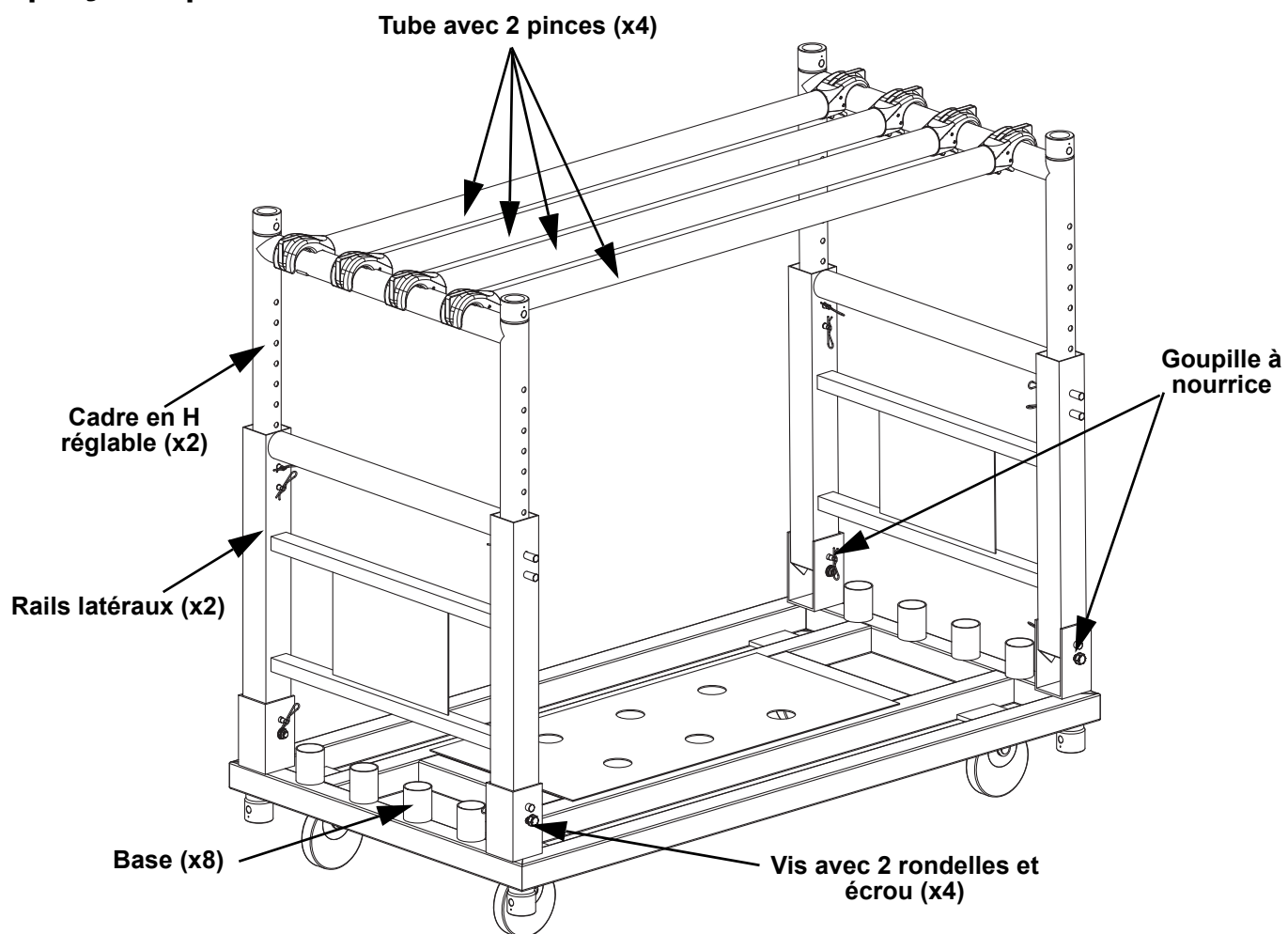

Setup

1. Pour commencer la configuration :
 - a. Soulevez chaque rail latéral du CP Rack en retirant les goupilles à la base de chaque rail latéral.

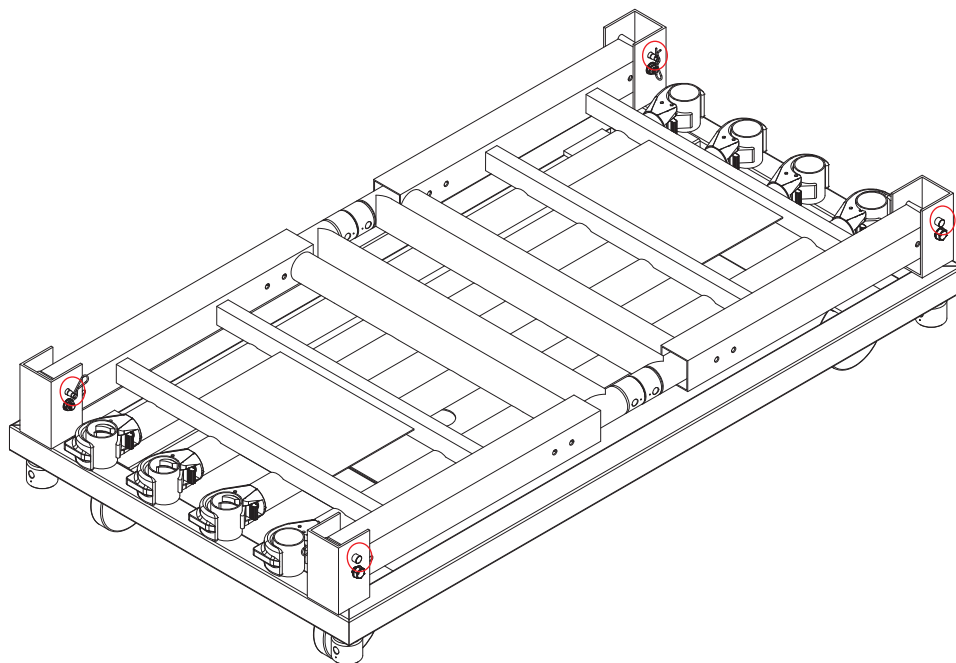

- b. Pour retirer la goupille, retirez d'abord le clip de sécurité.

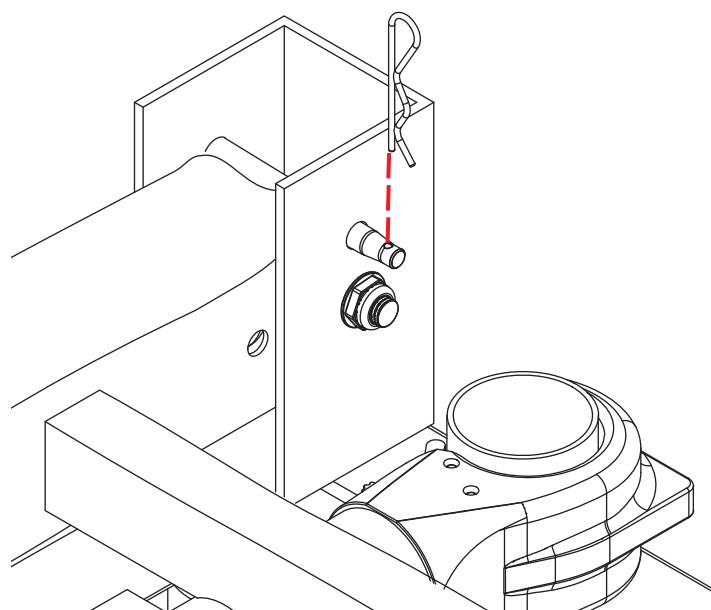

c.

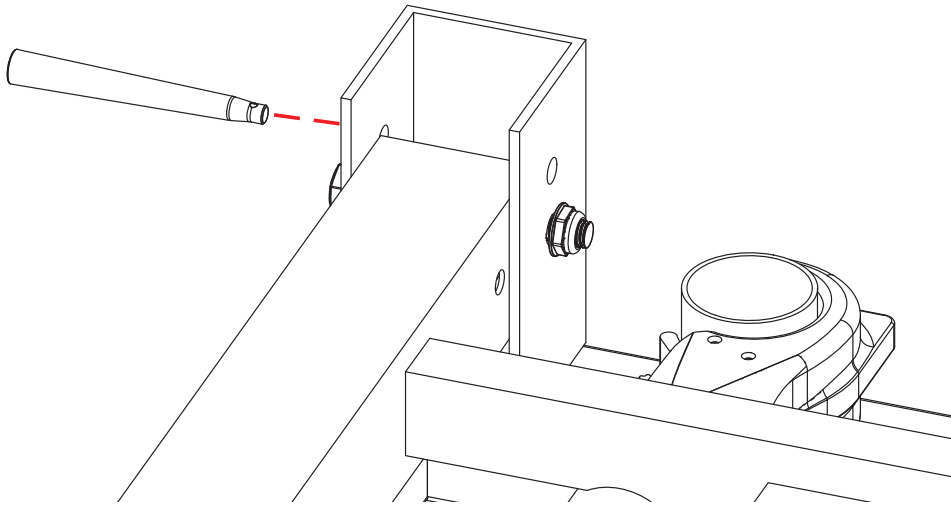

d.

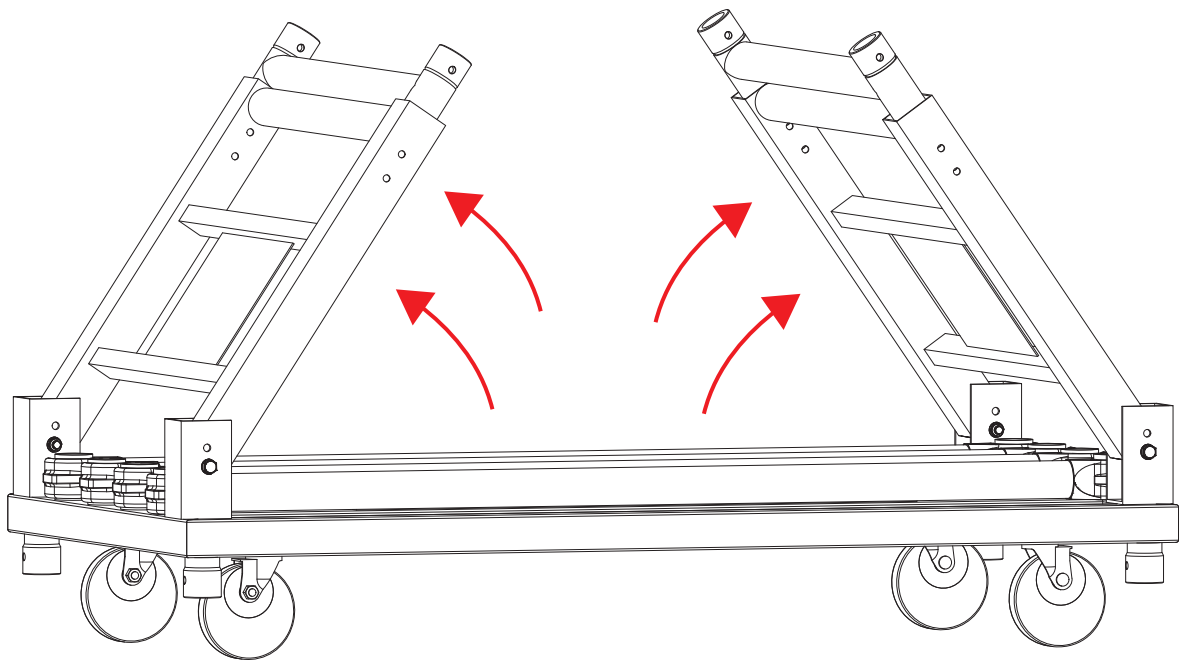

e.

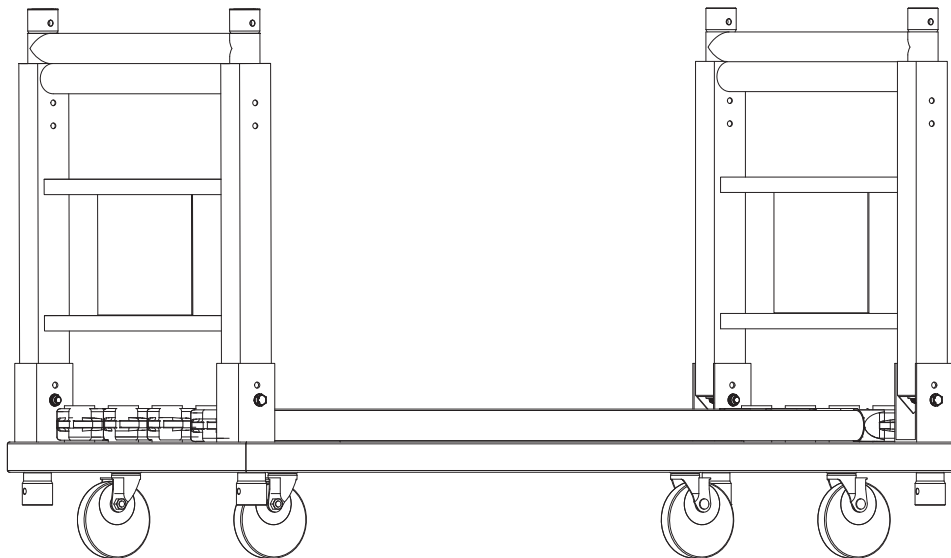

Il est possible de supprimer les deux cadres en H du CP Rack. Les cadres en H peuvent ensuite être suspendus à une ferme.

f. Insérez la goupille pour verrouiller le rail latéral en position verticale.

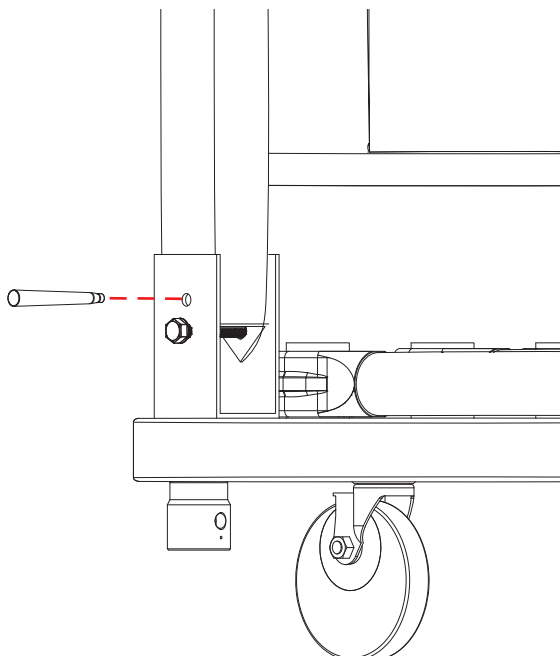

g. Insérez le clip de sécurité dans la goupille.

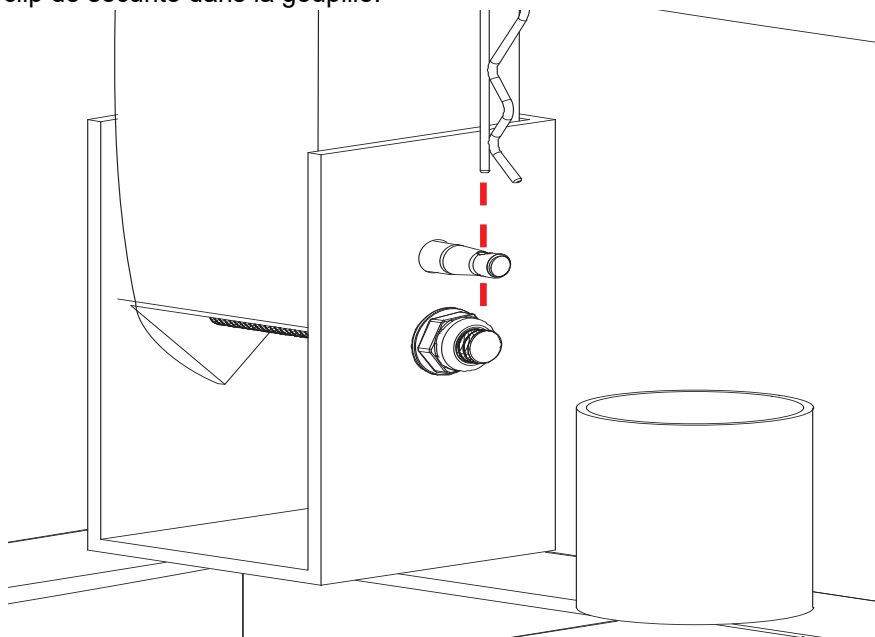

h. Répétez les étapes 1-f et 1-g avec toutes les bases pour verrouiller les rails latéraux.

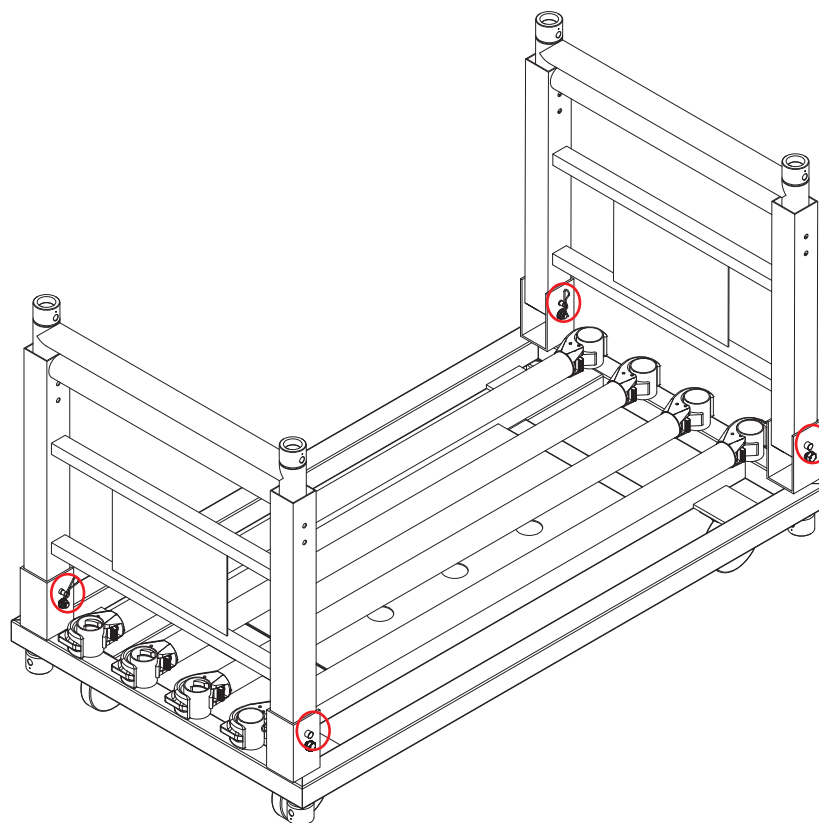

Attention ! Assurez-vous que tous les points de fixation sont bien serrés. Le non-respect de cette consigne peut entraîner des risques pour la sécurité !

2. Pour détacher les tubes des bases :
 - a. Relâchez la pince en appuyant sur l'interrupteur.

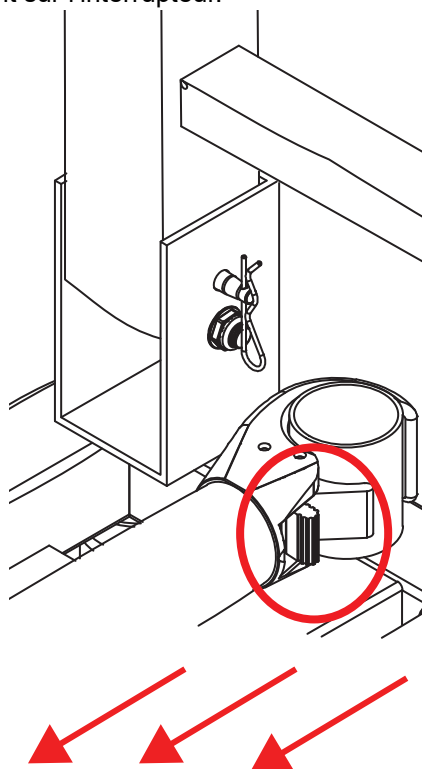

- b. Retirez le tube.

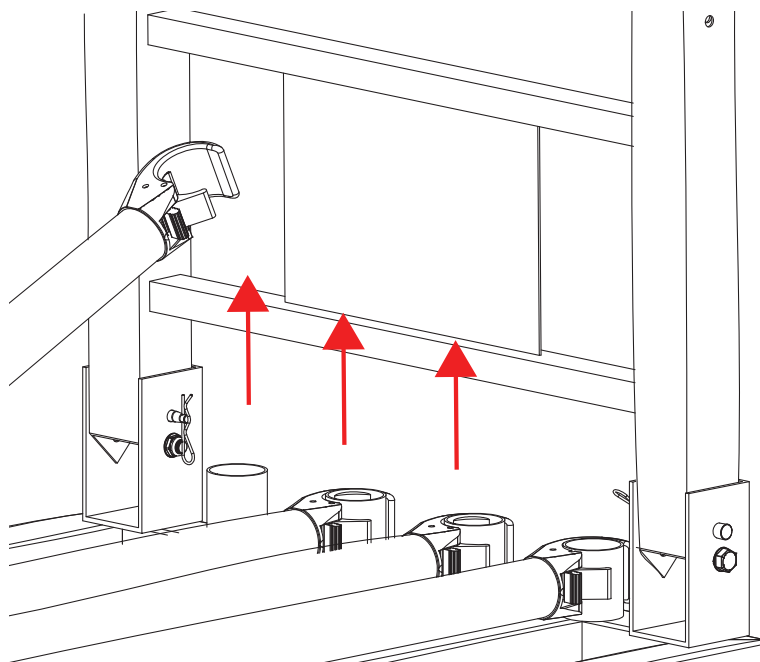

- c. Répétez la procédure avec l'autre pince pour libérer complètement le tube.

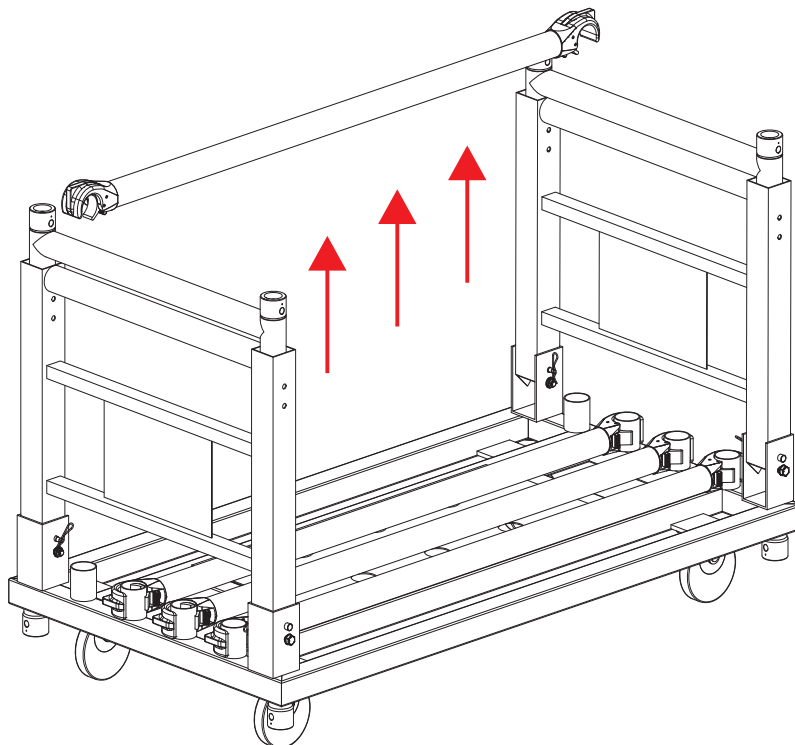

3. Pour connecter le(s) tube(s) aux cadres en H :

- a. Assurez-vous que la pince est orientée vers le bas et appuyer sur la pince de la barre horizontale du cadre en H.

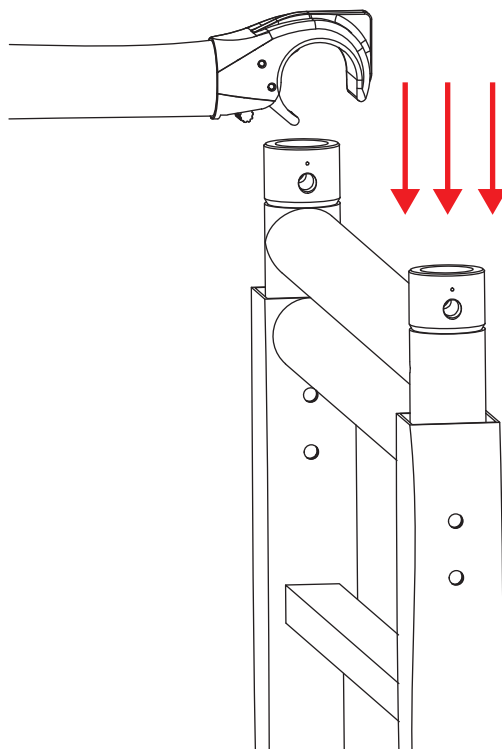

- b. Assurez-vous que la pince est fermement fixée au cadre en H.

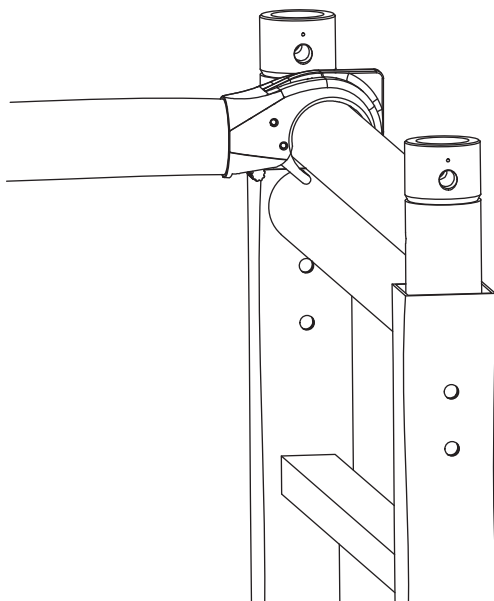

- c. Répétez les étapes précédentes avec tous les autres tubes souhaités :

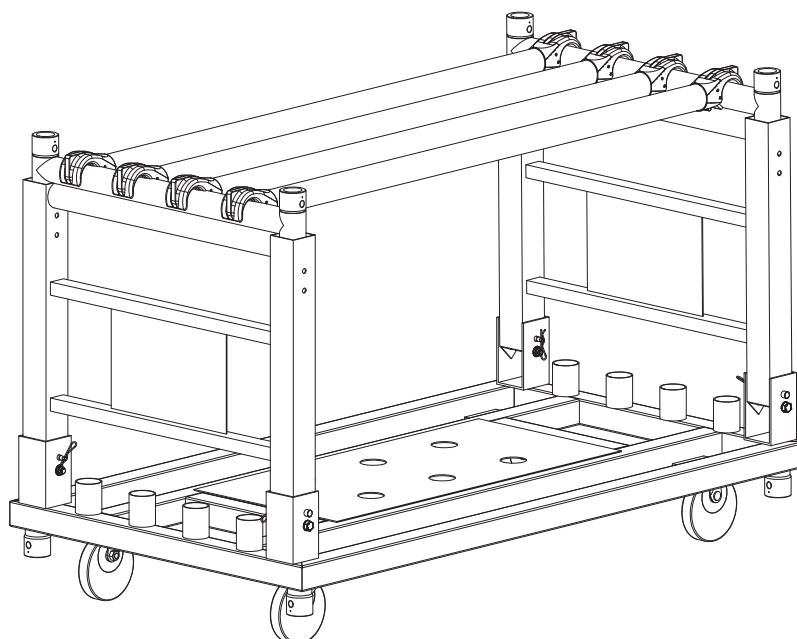

La capacité de charge maximale de ce produit est de 450 kg. Ne dépassez pas ce poids, car le non-respect de cette consigne peut entraîner des risques pour la sécurité.

4. Il est possible de rallonger les cadres H pour doubler la hauteur des CP Rack. Pour étendre les cadres en H :
 - a. Retirez les clips de sécurité qui verrouillent le cadre en H en place.
 - b. Étendez ou abaissez la goupille à la hauteur désirée.

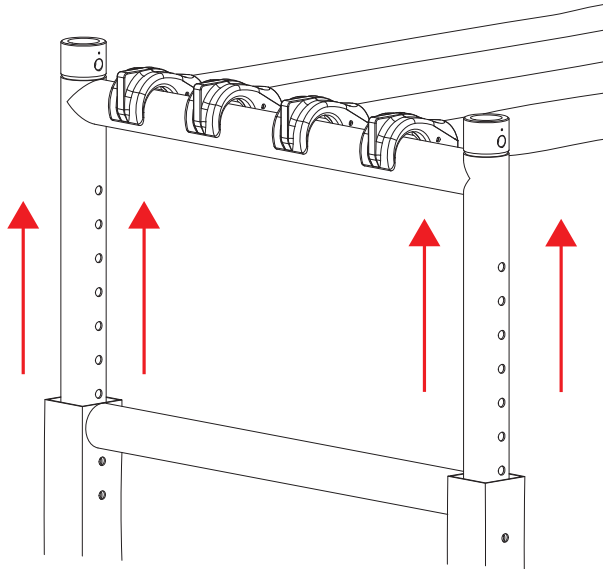

- c. Réinsérez les clips de sécurité et les goupilles pour stabiliser les cadres en H à la hauteur souhaitée.

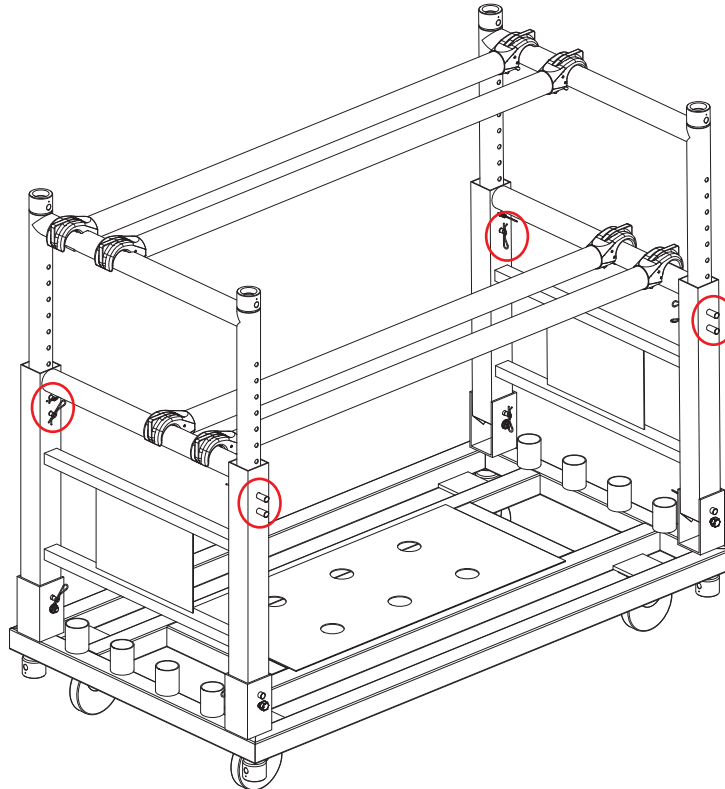

Il est possible d'empiler un autre CP Rack en haut de ce produit. L'empilement maximum est de 2 produits en hauteur.

Transport sur ferme ou bâtis

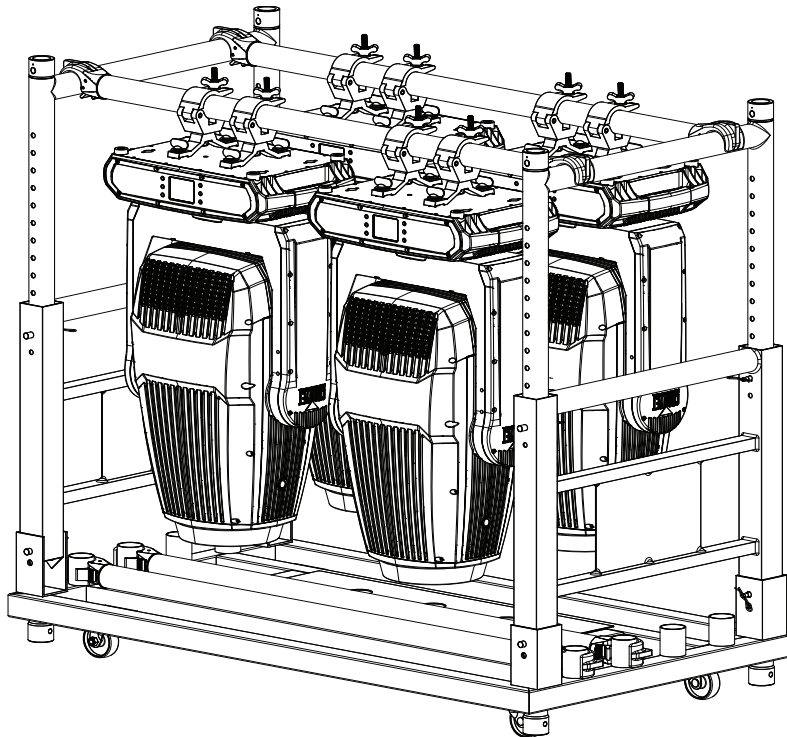

Lors du transport des appareils sur des supports de transport et des fermes pré-montées, montez les appareils en position verticale avec les lentilles tournées vers le bas et les verrous de panoramique et d'inclinaison engagés. Ceci permet d'éviter toute contrainte excessive sur les verrous d'inclinaison et de limiter la quantité de rebond hors axe sur les composants internes.

Sicherheitshinweise

Diese Sicherheitshinweise enthalten wichtige Informationen zu Installation, Nutzung und Wartung des CP Rack.

- **FOLGENDES SOLLTEN SIE NIEMALS TUN:**





- Nicht für Installation im Freien an Orten mit extremen Umweltbedingungen geeignet. Dies beinhaltet, ist aber nicht beschränkt auf:
 - Exposition in einer Meeres-/Salzwasserumgebung (innerhalb von 3 Meilen um einen Salzwasserkörper).
 - Das Produkt an Orten betreiben, an denen die normalen Temperaturen die in diesem Handbuch angegebenen Temperaturbereiche überschreiten.
 - Orte, die überschwemmungsgefährdet sind oder unter Schnee begraben werden.
 - Andere Bereiche, in denen das Produkt extremer Strahlung oder ätzenden Substanzen ausgesetzt ist.
- Im Falle einer schwerwiegenden Störung ist der Betrieb sofort einzustellen.

Lieferumfang

- CP Rack
- Umschalger
- Kurzanleitung

Symbole

Symbole	Bedeutung
	Wichtige Informationen zur Installation, Konfiguration und zum Betrieb. Bei Nichtbeachtung dieser Informationen kann es zu Fehlfunktionen oder Beschädigungen des Geräts oder zu Verletzungen des Bedieners kommen.
	Wichtige Informationen zur Installation oder Konfiguration. Wenn diese Informationen nicht beachtet werden, kann es zu Fehlfunktionen kommen.
	Nützliche Informationen.

Produktübersicht

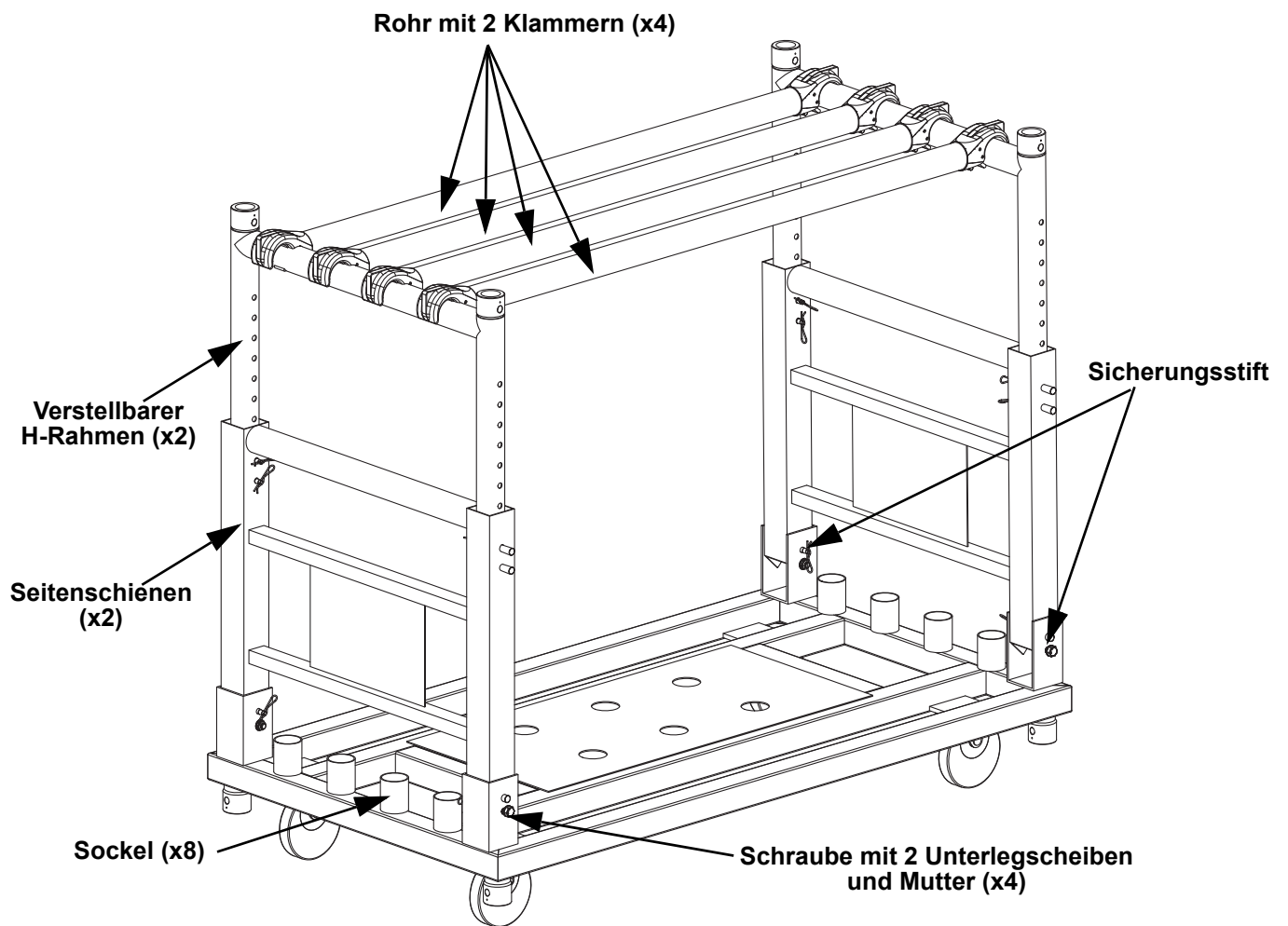

Aufbau

1. So beginnen Sie den Aufbau:
 - a. Stellen Sie die Seitenschienen des CP Rack auf, indem Sie die Sicherungstifte am Sockel an beiden Seitenschienen entfernen.

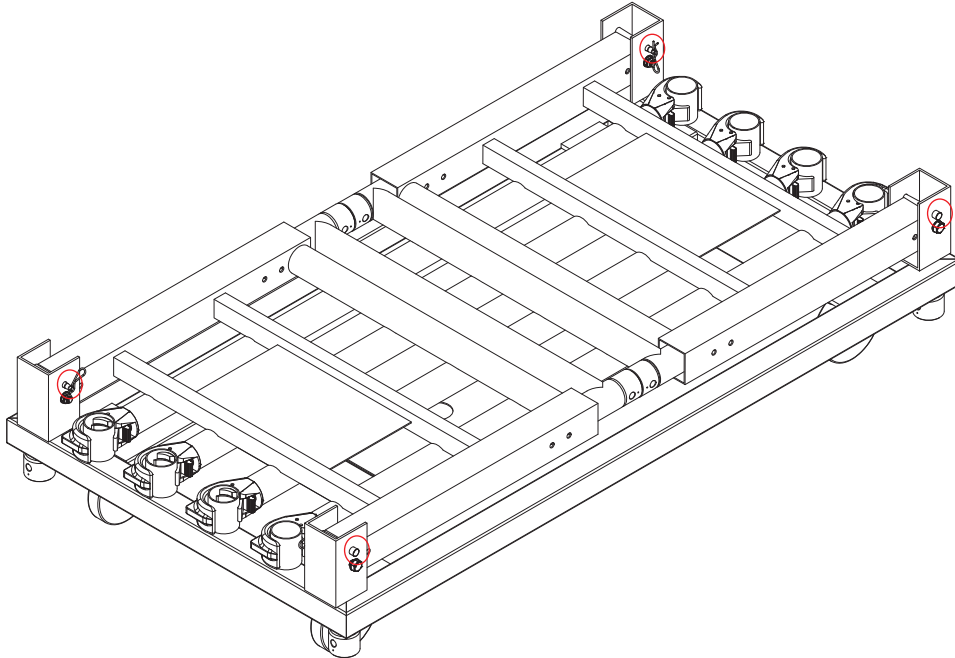

- b. Zum Entfernen eines Sicherungstiftes muss zunächst der Splint entfernt werden.

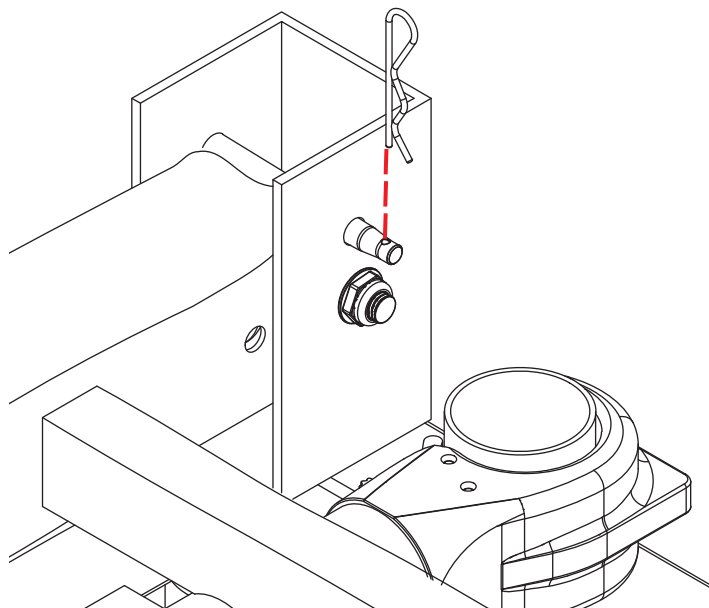

c.

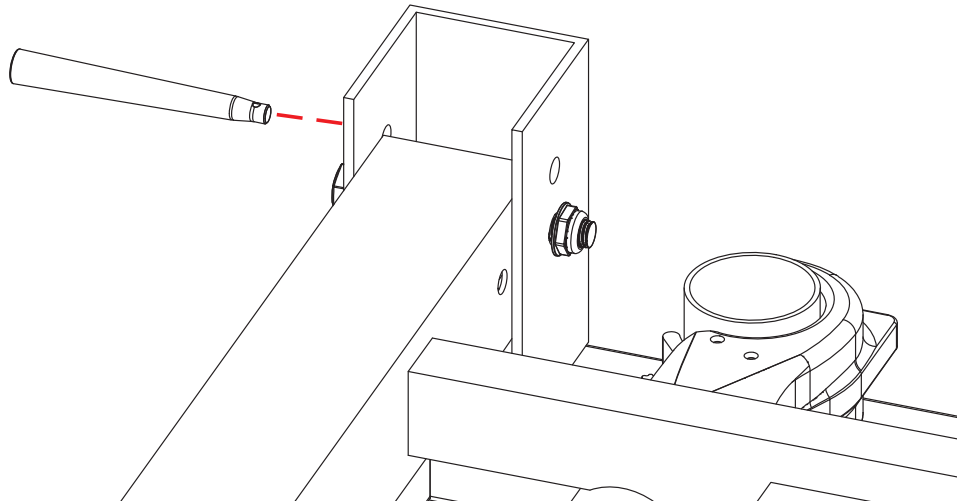

d.

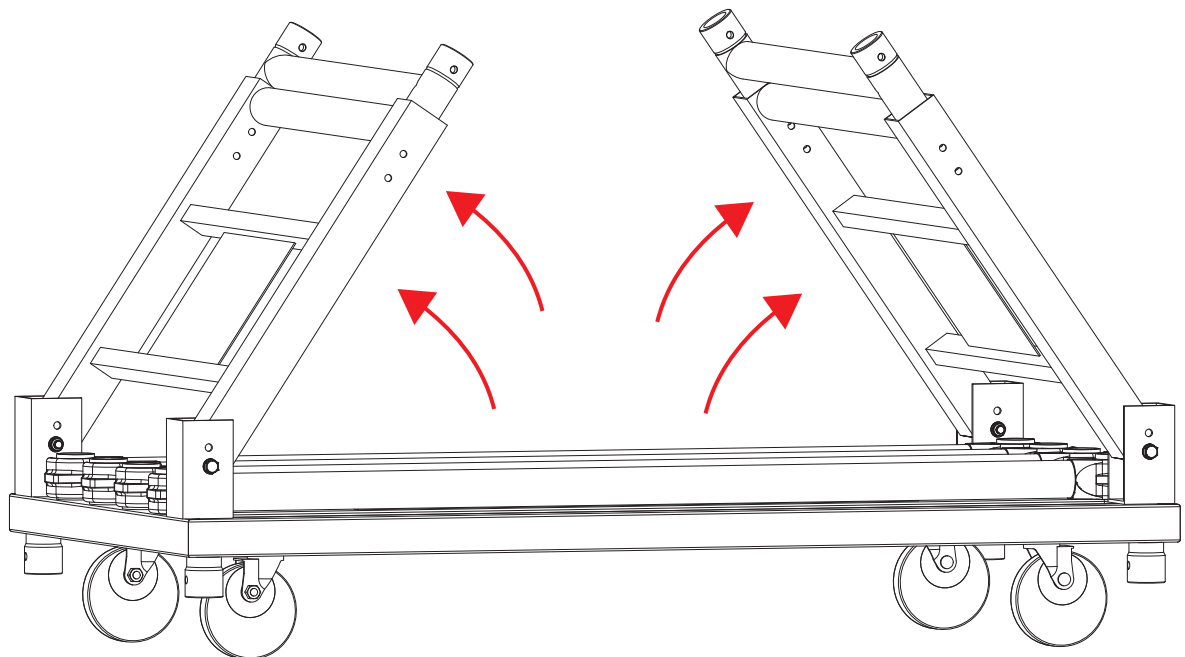

e.

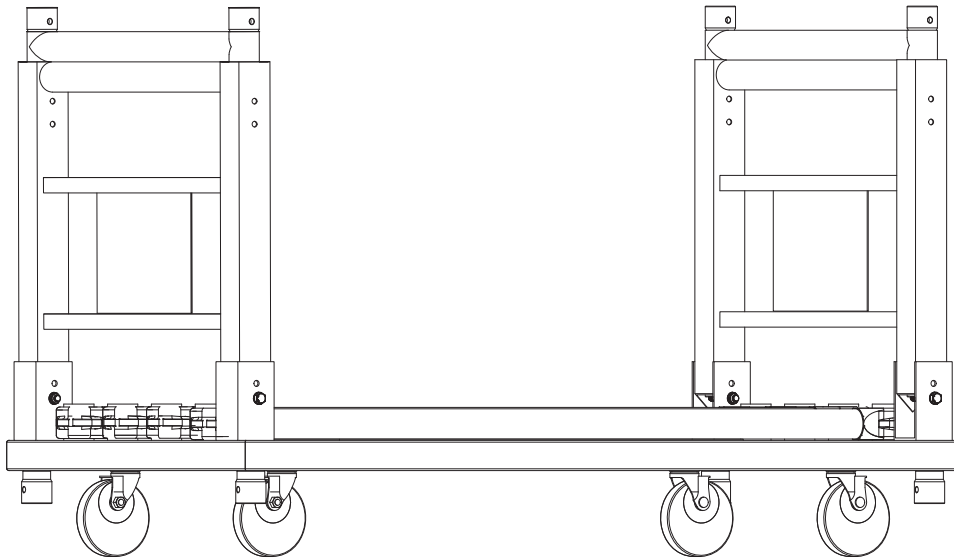

Beide H-Rahmen können vom CP Rack abgenommen werden. Die H-Rahmen können an einem Gerüst aufgehängt werden.

f. Setzen Sie den Sicherungsstift wieder ein, um die Seitenschiene in der aufrechten Position zu sichern.

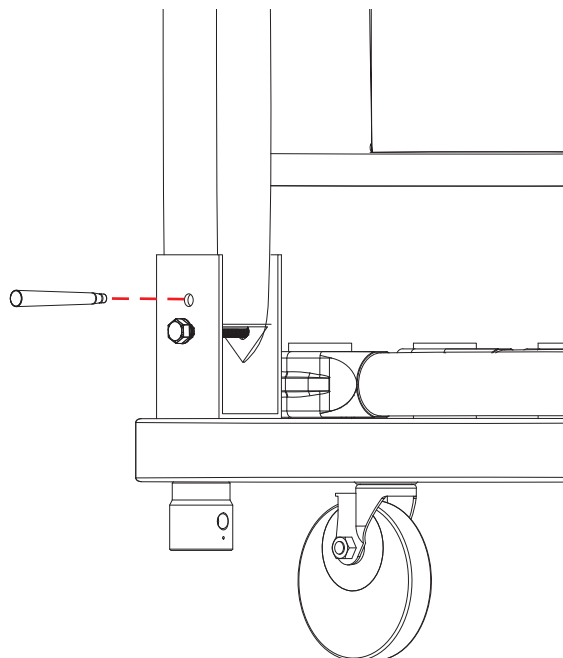

- g. Sichern Sie den Sicherungsstift mit dem Splint.

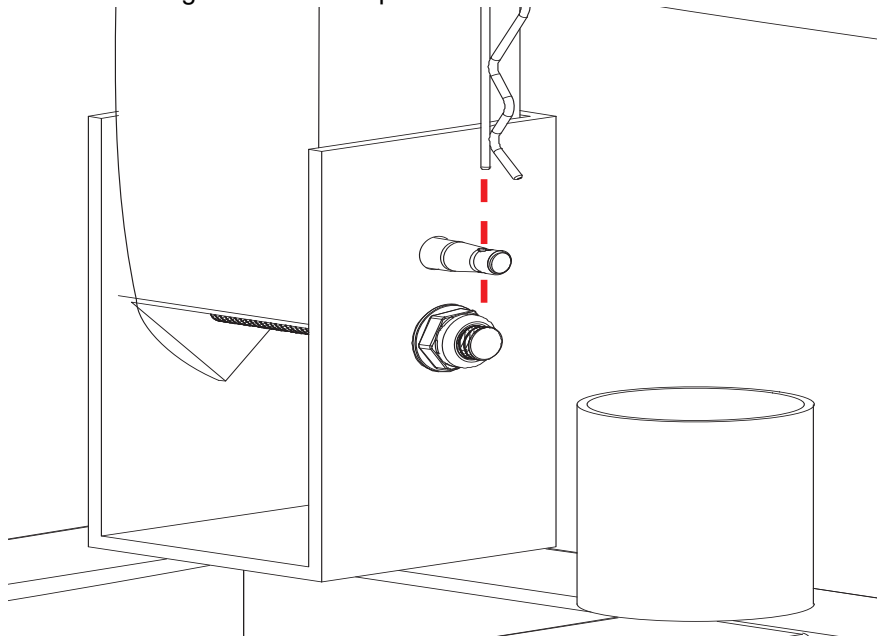

- h. Wiederholen Sie die Schritte 1-f und 1-g an allen Sockeln, um die Seitenschienen zu sichern.

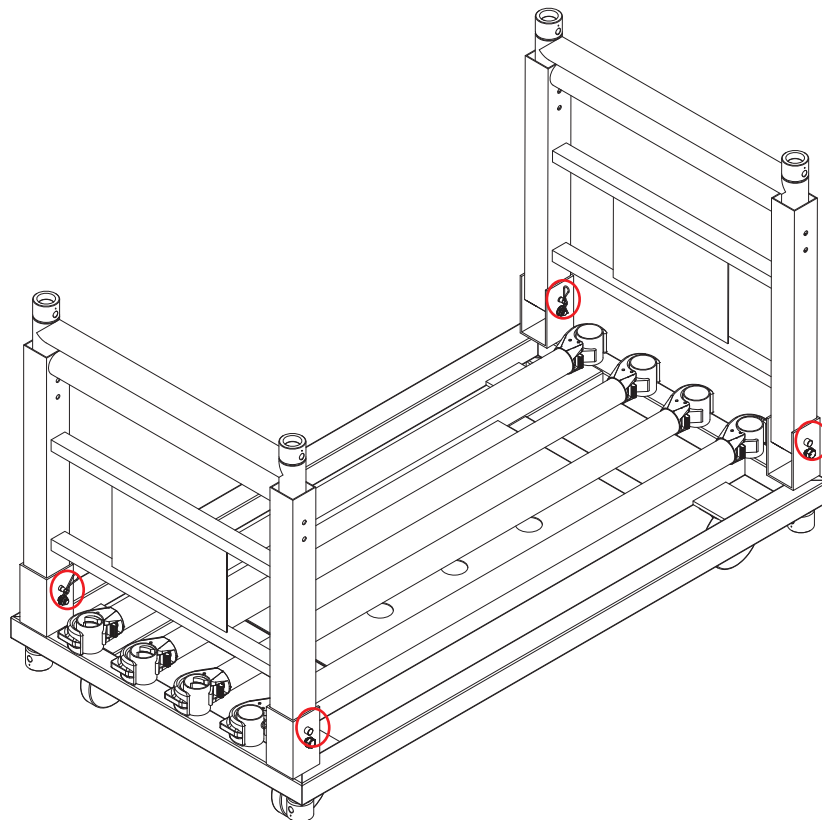

Warnung! Stellen Sie sicher, dass alle Sicherungsstifte eingesetzt und mit Splinten gesichert sind. Anderenfalls besteht ein hohes Sicherheitsrisiko!

2. So lösen Sie die Rohre von den Sockeln:
 - a. Lösen Sie die Klammer, indem Sie den Hebel entriegeln.

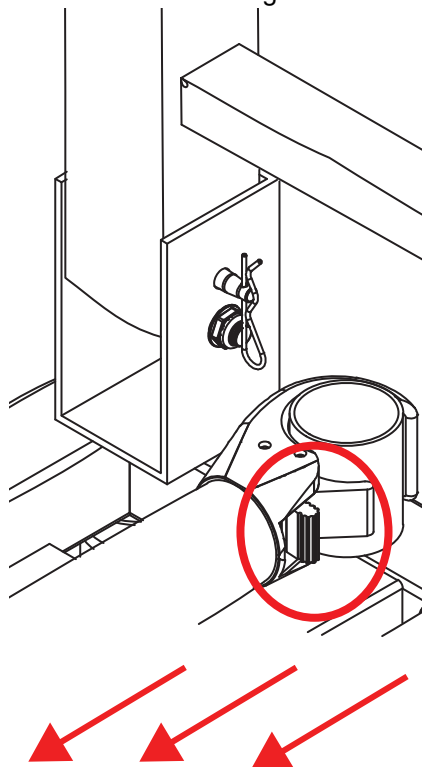

- b. Nehmen Sie das Rohr ab.

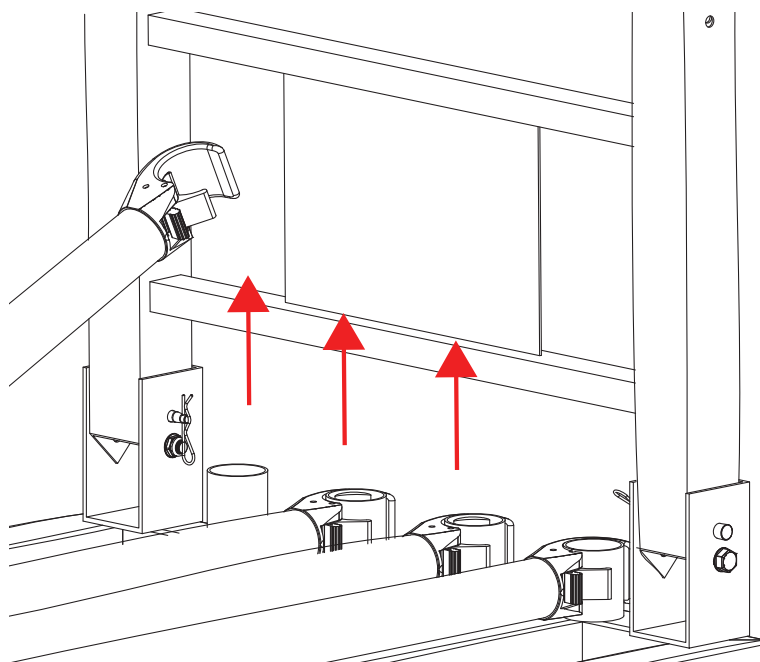

- c. Wiederholen Sie diese Schritte an der anderen Klammer, um das Rohr vollständig zu lösen.

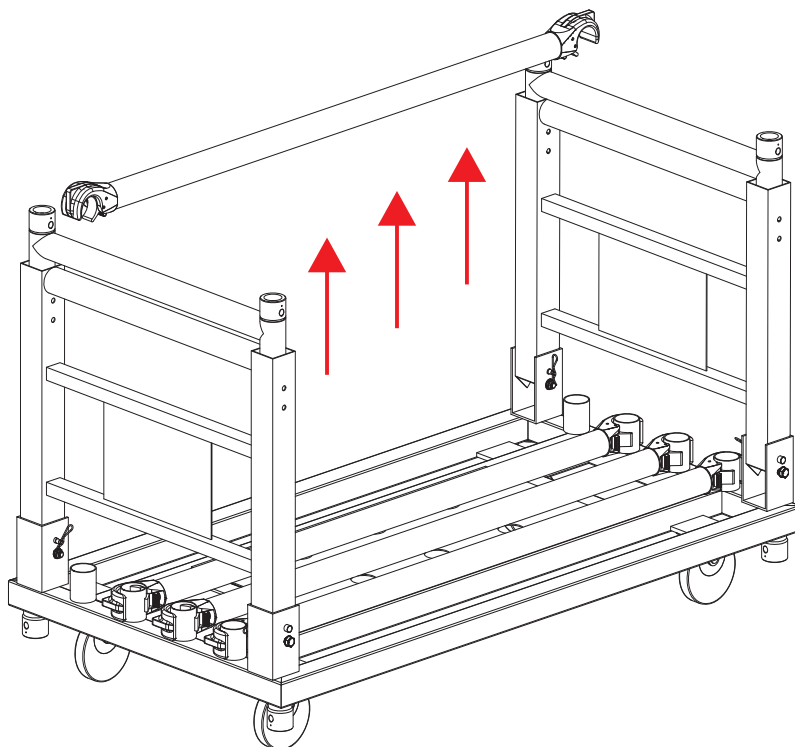

3. So verbinden Sie das Rohr bzw. die Rohre mit dem H-Rahmen:

- a. Stellen Sie sicher, dass die Klammer nach unten zeigt, und drücken Sie die Klammer auf die horizontale Stange des H-Rahmens.

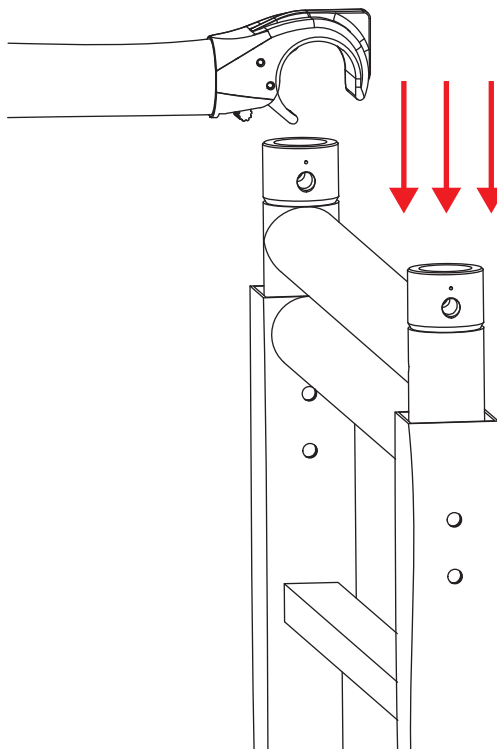

- b. Stellen Sie sicher, dass die Klammer fest mit dem H-Rahmen verbunden ist.

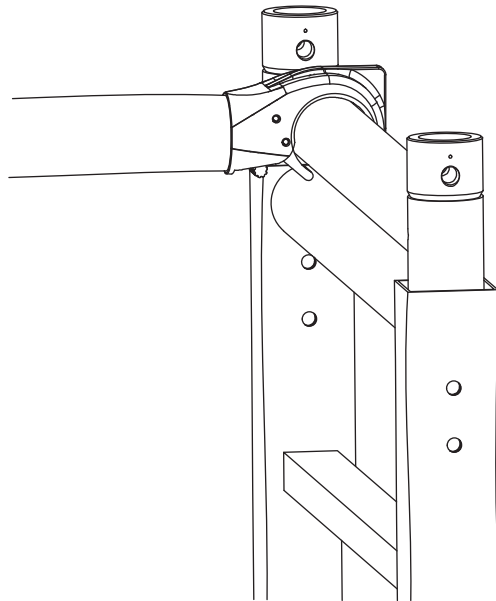

- c. Wiederholen Sie diese Schritte für alle weiteren gewünschten Rohre:

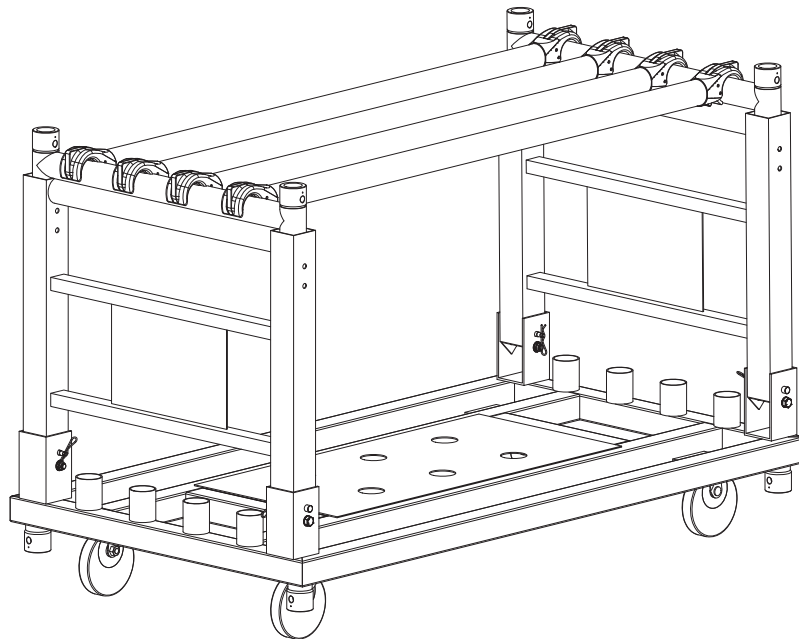

Die maximale Tragfähigkeit dieses Produktes beträgt 450 kg (1.000 lbs). Dieses Gewicht darf nicht überschritten werden, anderenfalls besteht ein hohes Sicherheitsrisiko!

4. Die H-Rahmen können bis zur doppelten Höhe des CP Rack verstellt werden. So verstellen Sie die H-Rahmen:
 - a. Entfernen Sie die Sicherungsstifte, die den H-Rahmen in Position halten.
 - b. Verstellen Sie den H-Rahmen auf die gewünschte Höhe.

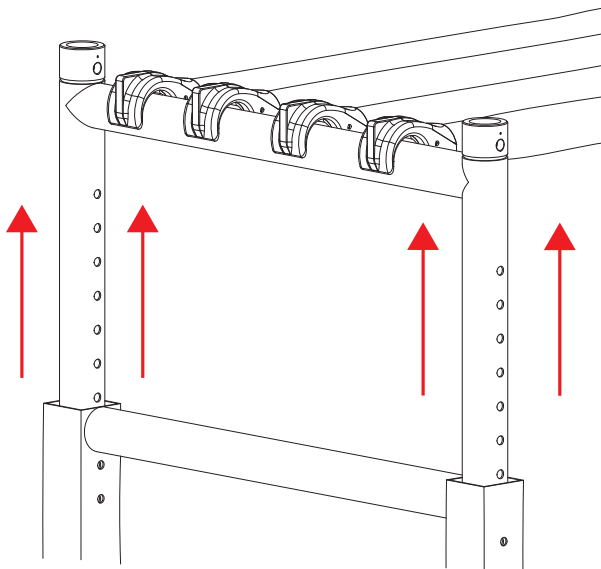

- c. Setzen Sie die Sicherungsstifte wieder ein und sichern Sie sie mit den Splinten, um den H-Rahmen in der gewünschten Höhe zu fixieren.

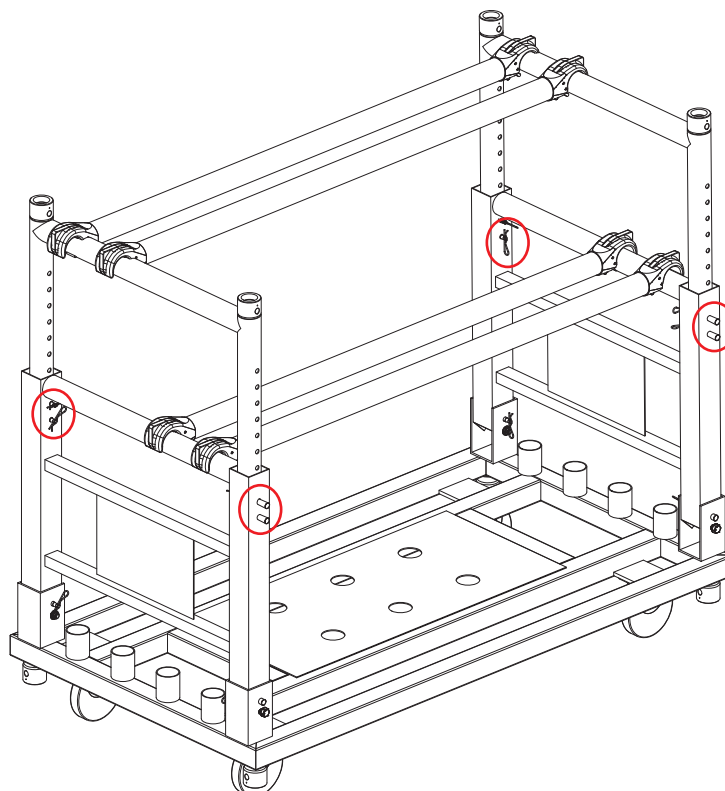

Ein weiterer CP Rack kann auf dieses Produkt aufgesetzt werden. Die maximale Stapelhöhe beträgt 2 Produkte.

Transport auf Traversen oder Gestellen

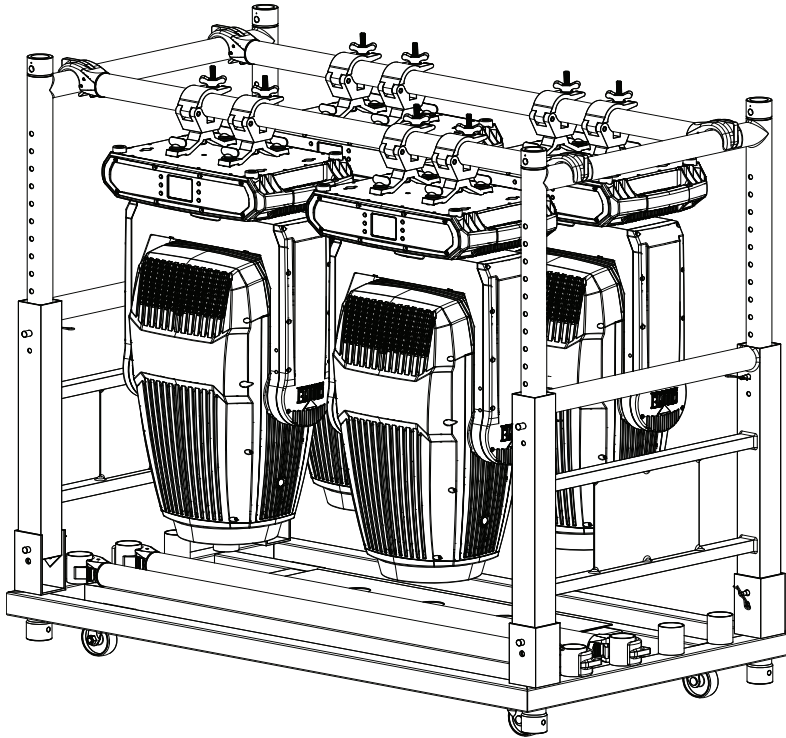

Wenn die Geräte in vorbereiteten Traversen- und Transportgestellen transportiert werden, müssen sie in vertikaler Position mit nach unten gerichteten Linsen und eingerasteten Schwenk- und Neigungssperren montiert werden. Dadurch werden übermäßige Beanspruchungen der Neigungssperren vermieden und die Auswirkungen der Achsabweichung auf die inneren Bauteile begrenzt.

Intentionally Left Blank Page

Veiligheidsvoorschriften

Deze veiligheidsvoorschriften bevatten belangrijke informatie over de installatie, het gebruik en het onderhoud van de CP Rack.





- **NOOIT:**
 - Het product permanent buiten installeren op een plek met extreme omgevingsfactoren. Dit omvat, maar is niet beperkt tot:
 - Blootstelling aan mariene/zilte omgevingen (binnen 5 km van zoutwatergebied).
 - Locaties waar de normale temperaturen hoger zijn dan de temperatuurbereiken aangegeven in deze handleiding.
 - Plaatsen die kwetsbaar zijn voor overstromingen of een zwaar sneeuwdek.
 - Andere gebieden waar het product onderhevig is aan extreme straling of bijtende stoffen.
 - Stop het gebruik onmiddellijk bij een ernstig probleem in de werking.

In de verpakking

- CP Rack
- Hoes
- Beknopte handleiding

Symbolen

Symbool	Betekenis
	Kritieke installatie-, configuratie- of bedieningsinformatie. Het negeren van deze informatie kan ervoor zorgen dat het product niet werkt, beschadigd raakt of leidt tot letsel van de gebruiker.
	Belangrijke installatie- of configuratie-informatie. Als deze informatie niet wordt gebruikt kan het product niet correct functioneren.
	Nuttige informatie.

Productoverzicht

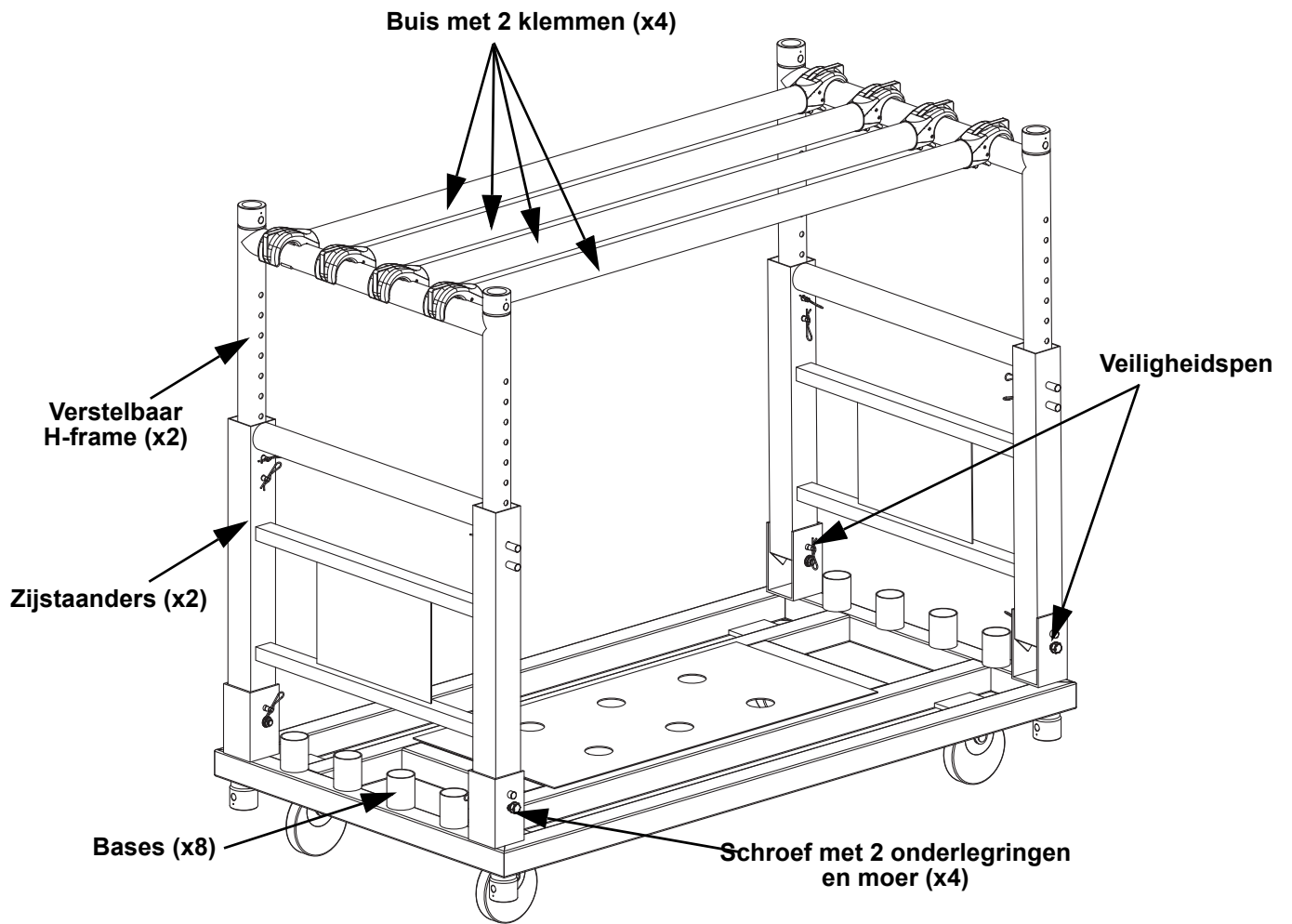

Opzetten

1. Om met het opzetten te beginnen:
 - a. Klap elke zijstaander van de CP Rack op na de veiligheidspen aan de basis van elke dwarsligger te hebben verwijderd.

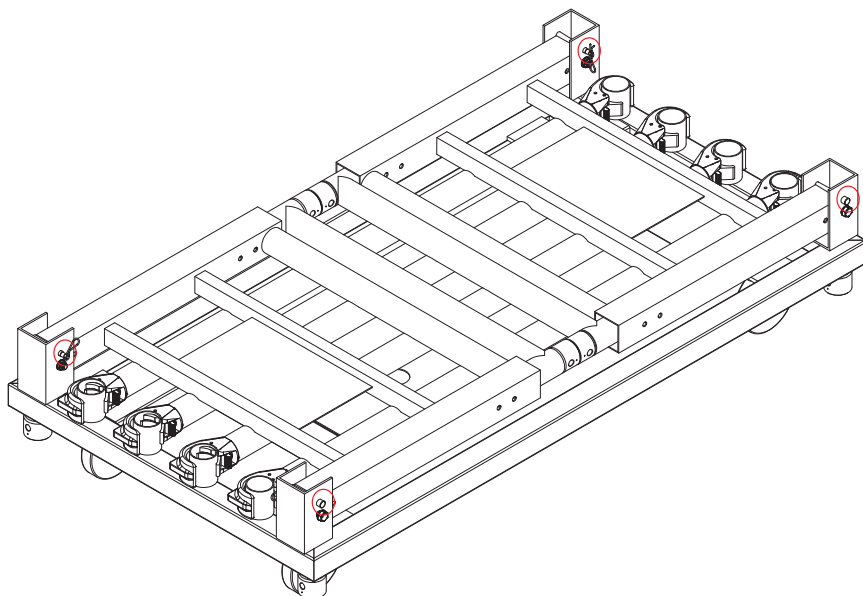

- b. De pen kan worden verwijderd nadat de veiligheidsclip is weggehaald.

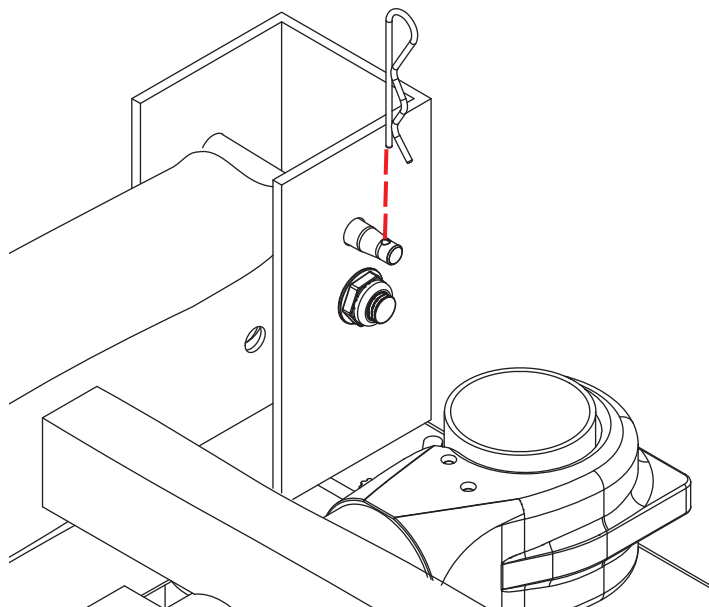

c.

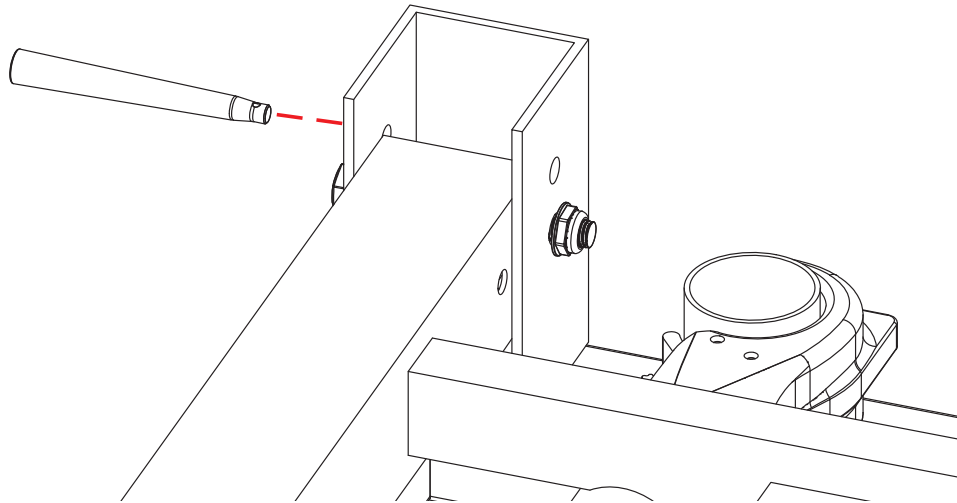

d.

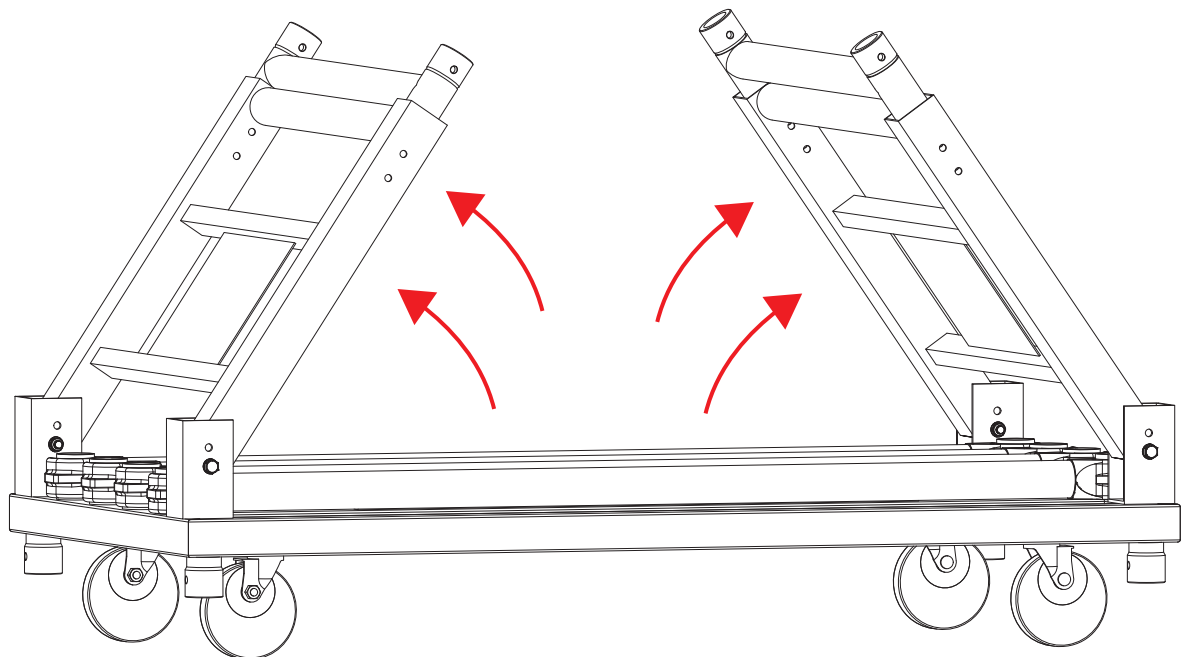

e.

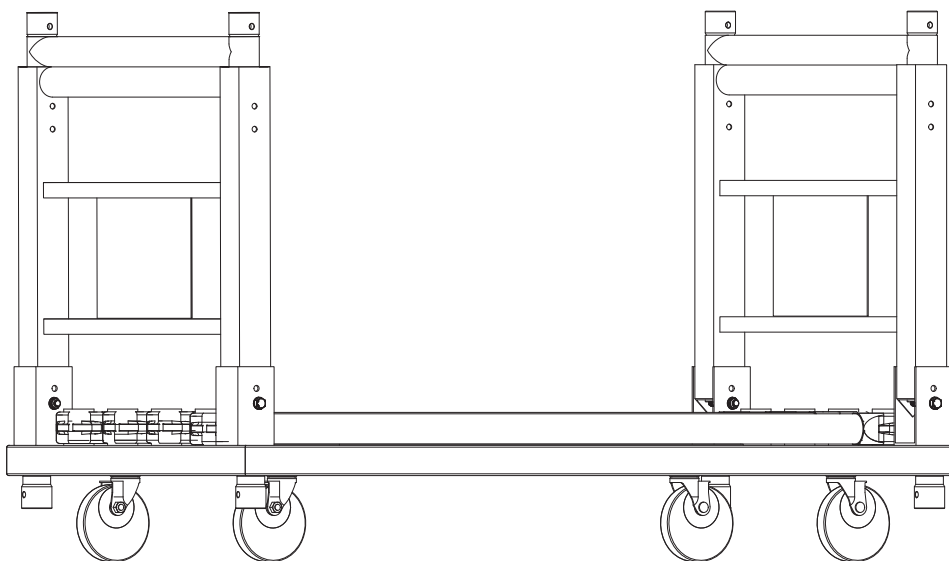

Het is mogelijk om beide H-frames van de CP Rack te verwijderen. Daarna kunnen de H-frames worden opgehangen aan een truss.

f. Steek de pin in de staander om deze rechtop vast te zetten.

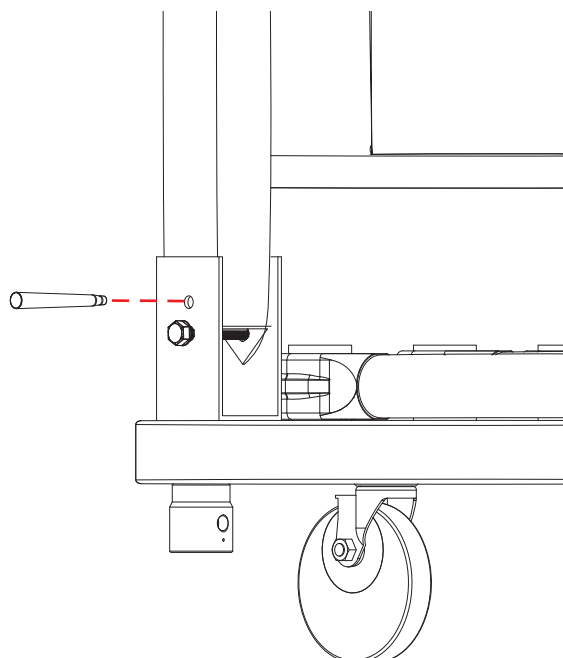

- g. Steek de veiligheidsclip in de pen.

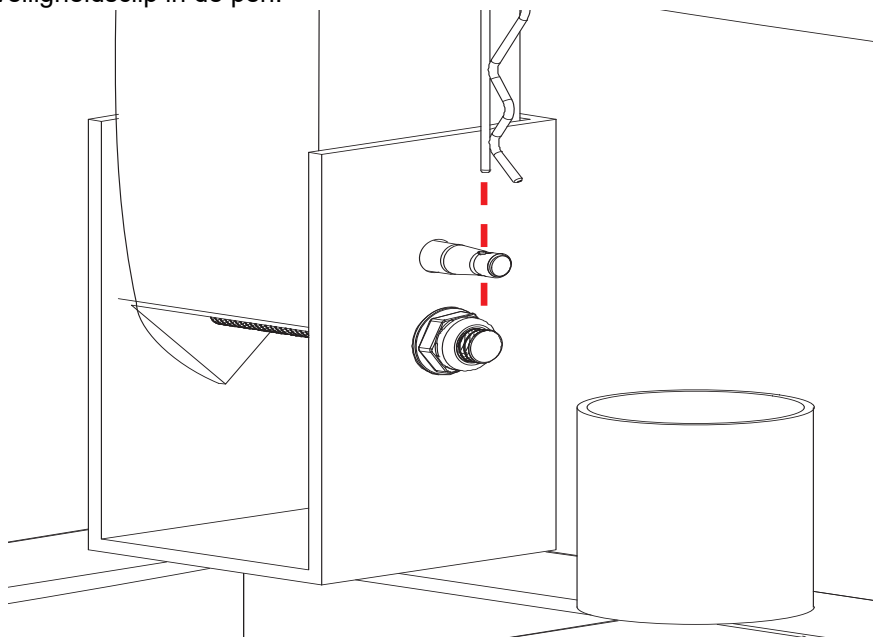

- h. Herhaal de stappen 1-f en 1-g op alle bases om de standers vast te zetten.

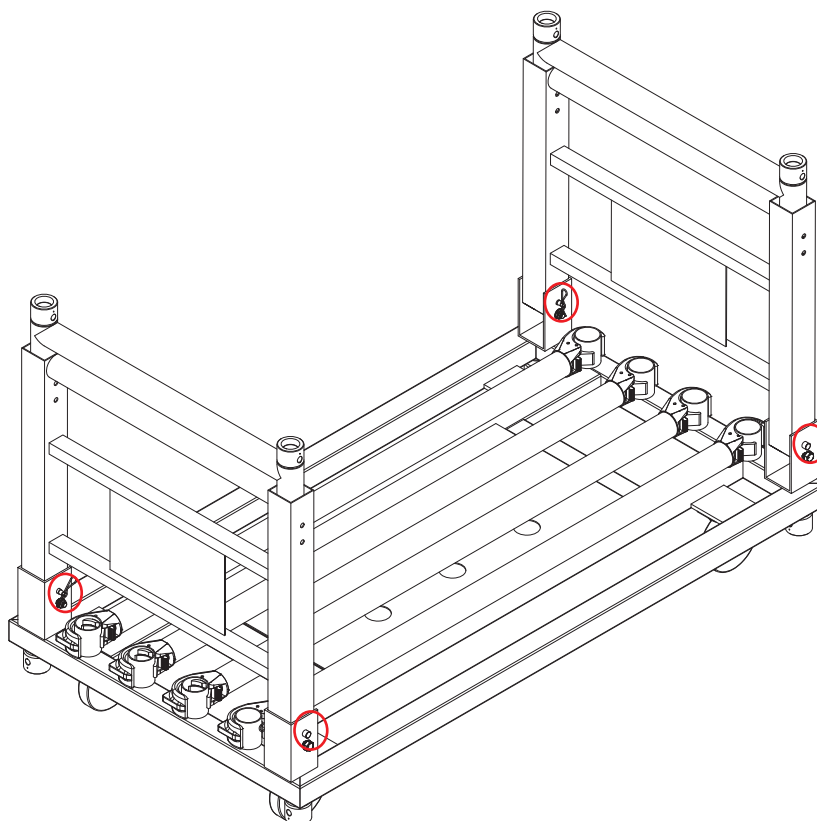

Waarschuwing! Zorg ervoor dat alle bevestigingspunten stevig vastzitten. Als dit achterwege wordt gelaten, kan dat gevaarlijk zijn voor de veiligheid!

2. De buizen worden als volgt losgemaakt van de bases:
 - a. Maak de klem los door de schakelaar in te drukken.

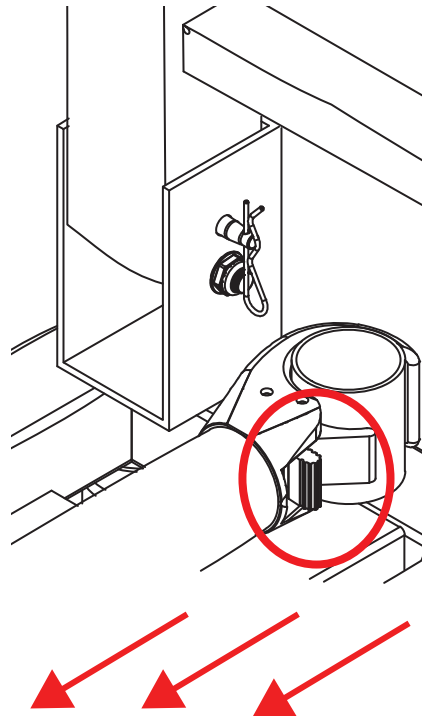

- b. Haal de buis weg.

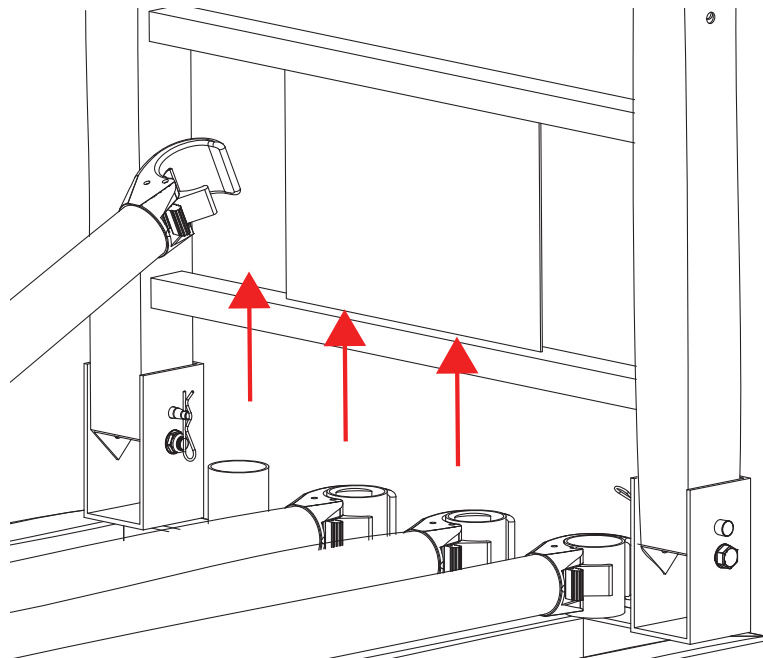

- c. Doe hetzelfde met de andere klem om de buis helemaal los te maken.

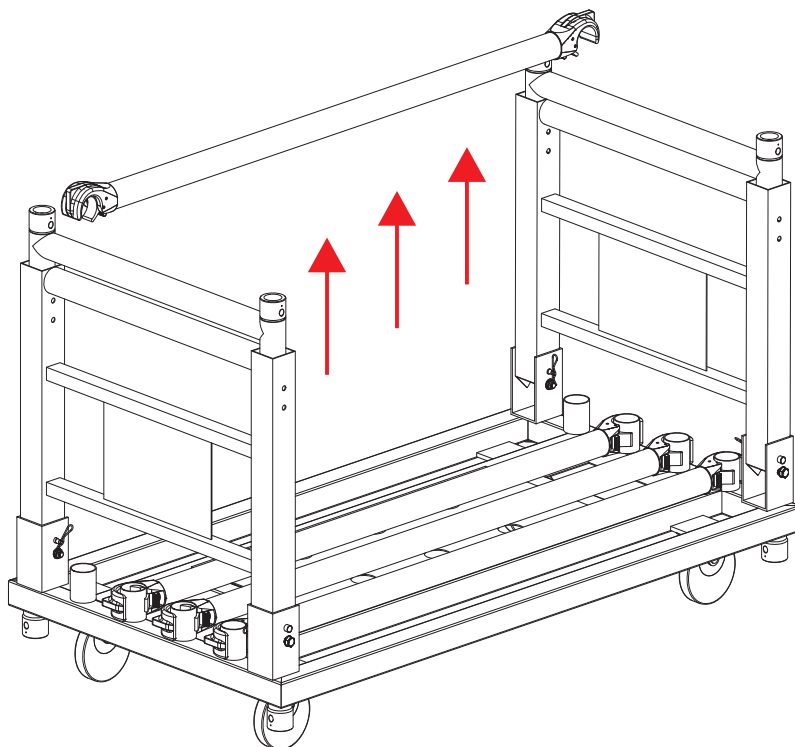

3. Buizen worden als volgt vastgemaakt aan de H-frames:

- a. Zorg dat de klem naar beneden is gericht en duw deze op de horizontale balk van het H-frame.

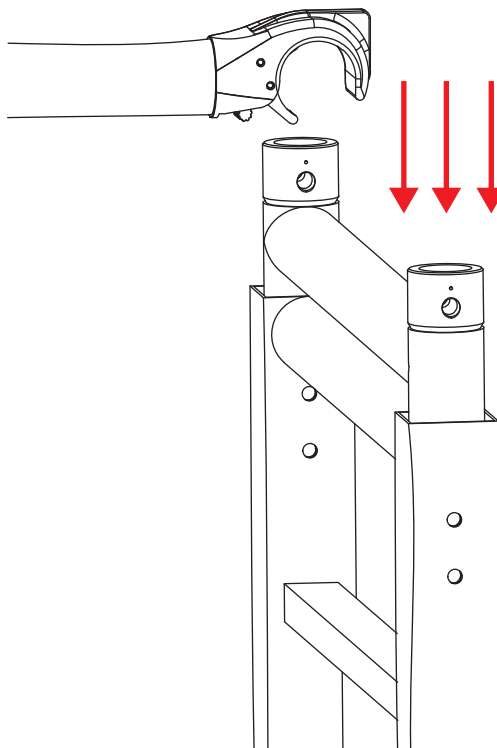

- b. Ga na of de klem stevig aan het H-frame vastzit.

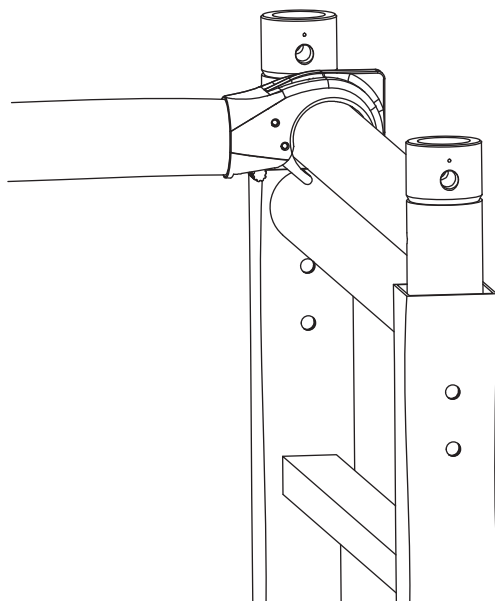

- c. Herhaal de vorige stappen desgewenst met eventuele andere buizen:

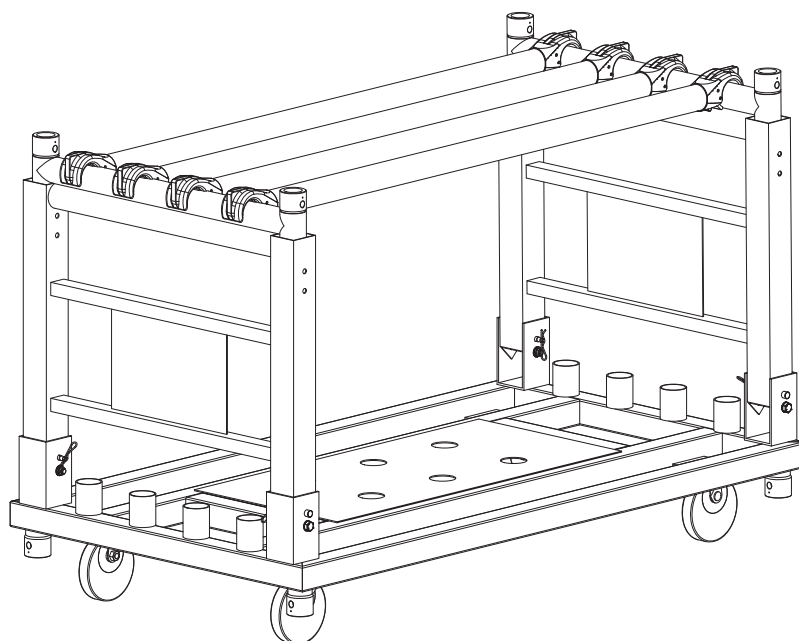

De maximale laadcapaciteit van dit product is 450 kg. Overschrijd dit gewicht niet, want anders kan de veiligheid in gevaar komen.

4. Het is mogelijk om de H-frames uit te schuiven tot de dubbele hoogte van de CP Rack. De H-frames worden als volgt uitgeschoven:
 - a. Verwijder de veiligheidsclips waarmee het H-frame op zijn plaats gehouden wordt.
 - b. Verplaats de poten omhoog of omlaag tot de gewenste hoogte.

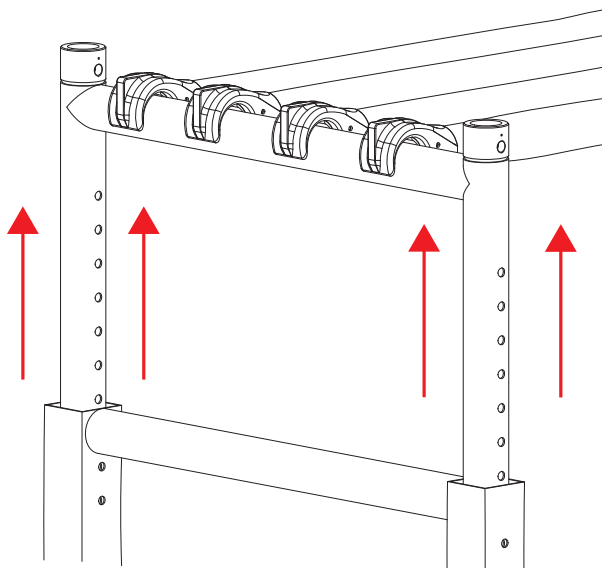

- c. Steek de veiligheidsclips en -pennen er weer in om de H-frames op de gewenste hoogte vast te zetten.

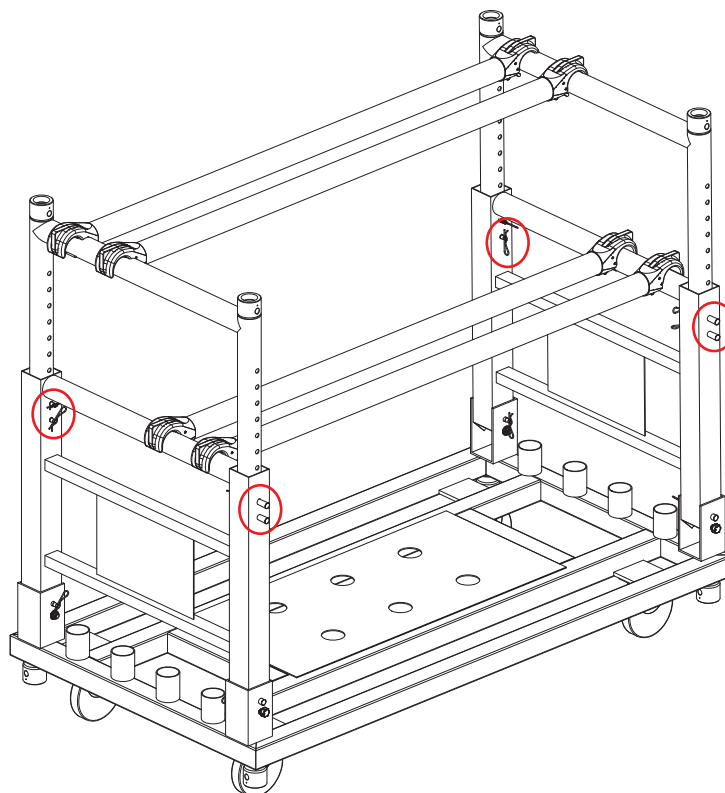

Het is mogelijk om een andere CP Rack bovenop dit product te plaatsen.
Er mogen maximaal 2 producten worden gestapeld.

Transport op truss of racks

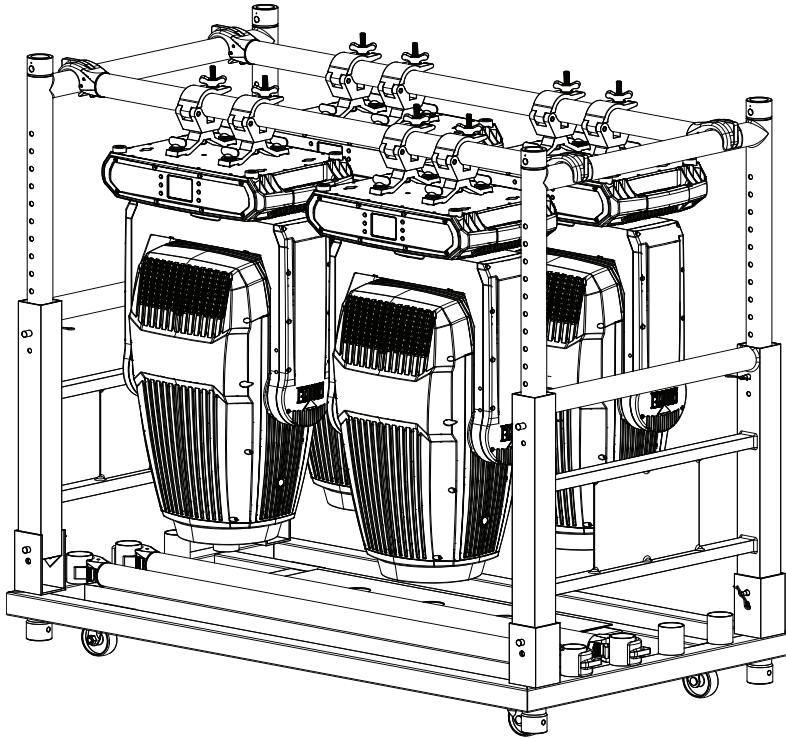

Bij het transporteren van armaturen in een voormonteerde truss en transportracks, moeten de armaturen in verticale positie worden bevestigd met de lenzen naar beneden gericht en de vergrendelingen van de pan-en kantelbeweging vastgezet. Dit om onnodige belasting op de kantelvergrendelingen te voorkomen en stuiterkrachten buiten de as op inwendige componenten te beperken.

Intentionally Left Blank Page

Contact Us

General Information	Technical Support
Chauvet World Headquarters	
Address: 3360 Davie Rd., Suite 509 Davie, FL 33314 Voice: (954) 577-4455 Fax: (954) 929-5560 Toll Free: (800) 762-1084	Voice: (844) 393-7575 Fax: (954) 756-8015 Email: chauvetcs@chauvetlighting.com Website: www.chauvetdj.com
Chauvet U.K.	
Address: Pod 1 EVO Park Little Oak Drive, Sherwood Park Nottinghamshire, NG15 0EB UK Voice: +44 (0) 1773 511115 Fax: +44 (0) 1773 511110	Email: UKtech@chauvetlighting.eu Website: www.chauvetdj.eu
Chauvet Benelux	
Address: Stokstraat 18 9770 Kruishoutem Belgium Voice: +32 9 388 93 97	Email: BNLtech@chauvetlighting.eu Website: www.chauvetdj.eu
Chauvet France	
Address: 3, Rue Ampère 91380 Chilly-Mazarin France Voice: +33 1 78 85 33 59	Email: FRtech@chauvetlighting.fr Website: www.chauvetdj.eu
Chauvet Germany	
Address: Bruno-Bürgel-Str. 11 28759 Bremen Germany Voice: +49 421 62 60 20	Email: DEtech@chauvetlighting.de Website: www.chauvetdj.eu
Chauvet Mexico	
Address: Av. de las Partidas 34 - 3B (Entrance by Calle 2) Zona Industrial Lerma Lerma, Edo. de México, CP 52000 Voice: +52 (728) 690-2010	Email: servicio@chauvet.com.mx Website: www.chauvetdj.mx

Visit the applicable website above to verify our contact information and instructions to request support. Outside the U.S., U. K., Ireland, Mexico, France, Germany, or Benelux, contact the dealer of record.



RoHS

